

MOUNTING BRACKET DETAILS

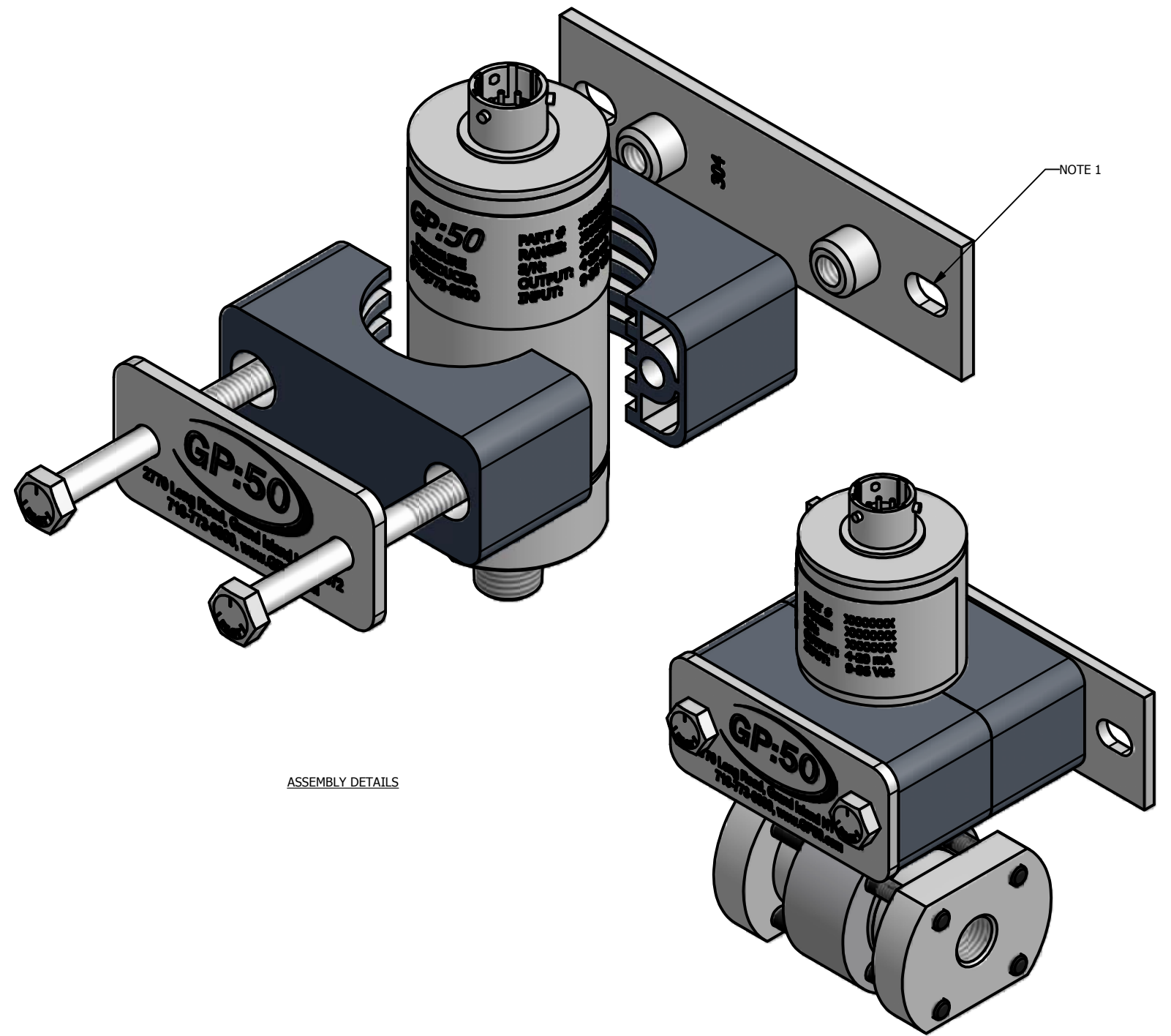

ASSEMBLY DETAILS

NOTES:

1. CUSTOMER TO SUPPLY MOUNTING SCREWS (NOT SHOWN).
2. MATERIAL:
INSERT = POLYPROPYLENE
METAL = 304 SST
3. P/N DOES NOT INCLUDE PRESSURE TRANSDUCER.

THIS IS A CONTROLLED DRAWING AND MAY NOT BE CHANGED W/O ENGINEERING AUTHORIZATION

UNLESS OTHERWISE SPECIFIED DIMENSIONS ARE IN INCHES		REVISIONS				GP-50 Aerospace Div.		2770 LONG ROAD GRAND ISLAND, NY 14072	
LET	DATE	BY	ECN	SIZE:	MATERIAL	DRAWN BY:	DATE		
				11 X 17		JH	8/14/2009		
TOLERANCES:				REVIEW	DATE	REVIEW	DATE	APPROVED	DATE
FRACTIONS ± 1/64						JH	9/8/2009		
DECIMALS:				TITLE:		DRAWING NO.		REV.	
.xx ± .01				TRANSDUCER MOUNT FOR		8P6-282.150304			
.xxx ± .005				1.50" DIAMETER CANS					
ANGLES ± 1/2°									
63-MACHINE FINISH (ALL SURFACES)									
REMOVE BURRS & BREAK SHARP									
EDGES .015 MAX.									
MACHINE FILLETS TO .015 R MAX.									
ALL DIAMETERS TO BE CONCENTRIC									
WITHIN .010 T.I.R.									
CHAMFER ALL MALE THREADS 45°±5°									
TO MINOR DIAMETER									
CHAMFER ALL FEMALE THREADS 90°±10°									
TO MAJOR DIAMETER									