



Installation Manual

GP:50 Differential Pressure Transmitters

GPIDP-A with 4 to 20 mA Output Signal

GPIDP-V with 1 to 5 VDC Output Signal

Installation, Calibration, Configuration, and Maintenance



Contents

Figures	iv
Tables	v
1. Introduction	1
General Description	1
Reference Documents	1
Transmitter Identification	1
Standard Specifications	2
Product Safety Specifications	5
2. Installation	8
Transmitter Mounting	8
Process Mounted Transmitter	9
Pipe or Surface Mounted Transmitter	9
Installation of Flow Measurement Piping	11
Filling System with Seal Liquid	13
Positioning Housing	13
Positioning Display	13
Cover Locks	14
Transmitter Wiring for GPIDP-A	15
Accessing Transmitter Field Terminals	15
Wiring the Transmitter to a Control Loop	16
Putting Transmitter into Operation	18
Taking the Transmitter Out of Operation	18
Transmitter Wiring for GPIDP-V	19
3 Wire Connection	19
4 Wire Connection	19
Wiring to a Control Loop	21
Putting Transmitter into Operation	23
Taking the Transmitter Out of Operation	23

3. Calibration and Configuration	25
Calibration Setup.....	25
Field Calibration Setup	25
Bench Calibration Setup	27
General Calibration Notes.....	28
Notes for Electronic Version -A and -V	29
Calibration and Configuration Using the Local Display	31
Calibration.....	33
GPIDP-A and GPIDP-V Calibration.....	34
Zero Adjustment Using External Zero Button	35
Configuration	35
GPIDP-A and GPIDP-V Configuration.....	37
Reranging an GPIDP-A or GPIDP-V Transmitter	39
GPIDP-A and GPIDP-V Character Lists.....	40
Testing the Display	41
Error Messages.....	42
4. Maintenance	45
Parts Replacement.....	45
Replacing the Electronics Module	45
Removing and Reinstalling the Housing Assembly.....	46
Replacing the Sensor Assembly.....	46
Replacing the Terminal Block Assembly	48
Rotating Process Covers for Venting.....	48
Index	51

Figures

1	Transmitter Identification.....	1
2	Minimum Allowable Absolute Pressure vs. Process Temperature with Fluorinert Fill Fluid.....	4
3	Process Mounted Transmitter	9
4	Mounting Transmitter to a Pipe or Surface.....	10
5	Example of Horizontal Process Line Installation.....	12
6	Example of Vertical Process Line Installation.....	12
7	Positioning Display	14
8	Accessing Field Terminals	15
9	Identification of Field Terminals.....	15
10	Supply Voltage and Loop Load.....	16
11	Loop Wiring	17
12	Wiring Several Transmitters to a Common Power Supply	18
13	Identification of Field Terminals.....	19
14	Three-Wire Connection.....	20
15	Four-Wire Connection.....	20
16	Loop Wiring	21
17	Wiring Several Transmitters to a Common Power Supply (Four-Wire)	22
18	Field Calibration Setup.....	27
19	Calibration Setup of Electronic Equipment	27
20	Bench Calibration Setup.....	28
21	Local Display Module.....	31
22	Top Level Structure Diagram.....	32
23	Calibration Structure Diagram	34
24	Configuration Structure Diagram.....	37
25	Display Test Segment Patterns.....	41
26	Replacing the Sensor Assembly	47
27	Replacing the Sensor Assembly (Code 78/79 pvdf Inserts).....	47
28	Sensor Cavity Venting and Draining.....	49

Tables

1	Electrical Safety Specifications.....	6
2	Calibration Menu.....	33
3	GPIDP-A and GPIDP-V Configuration Menu	35
4	Alphanumeric Character List	40
5	Numeric Character List	40
6	Error Messages.....	42

1. Introduction

General Description

The GPIDP-A and GPIDP-V Differential Pressure Transmitters measure the difference between two pressures applied to opposite sides of a silicon strain gauge microsensor within the sensor assembly. This microsensor converts differential pressure to a change in resistance. The resistance change is then converted to a 4 to 20 mA or 1 to 5 VDC signal proportional to differential pressure or to the square root of differential pressure. The measurement signal for the GPIDP-A is transmitted to remote receivers over the same two wires that supply power to the transmitter electronics.

The transmitters are often used for measuring fluid flow across a primary device such as an orifice plate, but can also be used for other types of differential pressure measurements such as liquid level, interface level, or density measurements.

Reference Documents

This document contains descriptions and instructions for transmitter installation, configuration, calibration, and maintenance.

Transmitter Identification

See Figure 1 for transmitter data plate contents. When the transmitter is powered, the firmware revision is shown on the top line of the display.

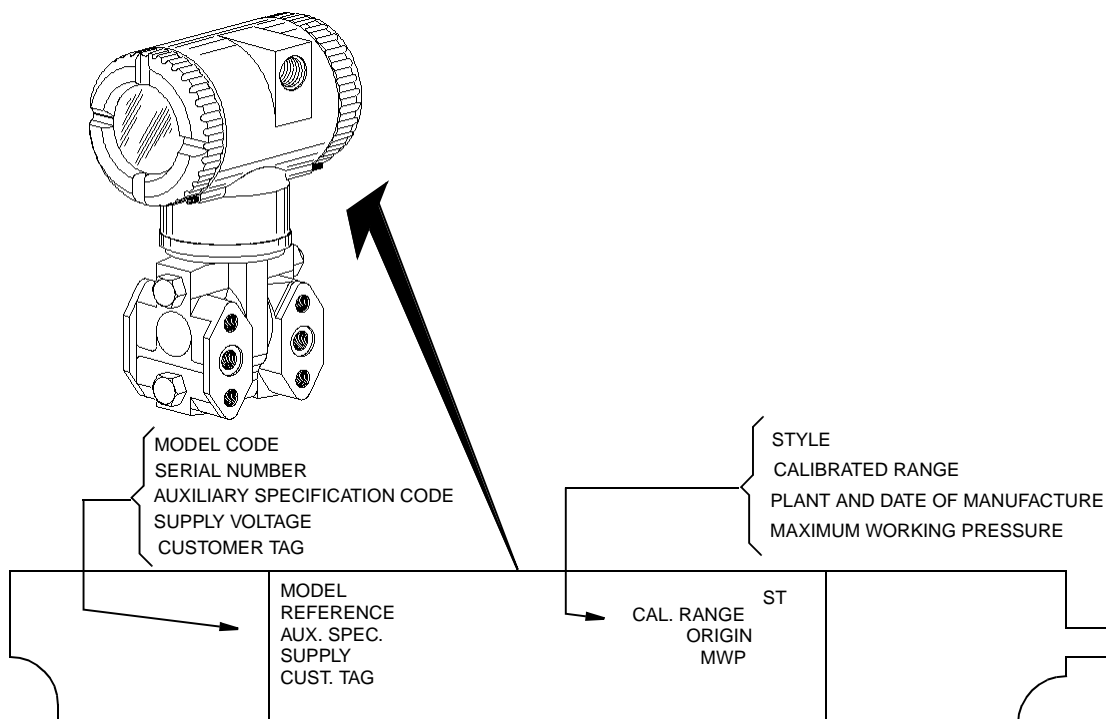

Figure 1. Transmitter Identification

Standard Specifications

Span and Range Limits

Span Limit Code	Span Limits ΔP	Range Limits ΔP
A	0.12 and 7.5 kPa (0.5 and 30 inH ₂ O)	-7.5 and +7.5 kPa (-30 and +30 inH ₂ O)
B	0.87 and 50 kPa (3.5 and 200 inH ₂ O)	-50 and +50 kPa (-200 and +200 inH ₂ O)
C	7.0 and 210 kPa (28 and 840 inH ₂ O)	-210 and +210 kPa (-840 and +840 H ₂ O)
D	0.07 and 2.1 MPa (10 and 300 psi)	-0.21 and +2.1 MPa (-30 and +300 psi)
E	0.7 and 21 MPa (100 and 3000 psi)	-0.21 and +21 MPa (-30 and +3000 psi)

Negative values of differential pressure indicate **low side** of sensor at the higher pressure.

Positive values indicate **high side** of sensor at the higher pressure.

Elevated Zero and Suppressed Zero

For applications requiring an elevated or suppressed zero, the maximum span and the upper and lower range limits of the transmitter can not be exceeded.

Transmitter Configuration Bolting Material	Maximum Static and Overrange Pressure Rating(a,e)		Proof Pressure Rating(b)	
	MPa	Psi	MPa	Psi
Standard (B7 steel), Option "-B2" (17-4 PS ss), Option "-D3" or "-D7"(c)	25	3625	100	14500
Option "B1" (316 ss) or Option "-D5"(c)	15	2175	60	8700
Option AS-B7M (B7M)	25	3625	100	14500
Option "-D1"(c)	16	2320	64	9280
Option "-D2", "-D4", "-D6", or "-D8"(c,d)	10	1500	40	6000

(a) Either side can be at the higher pressure during overrange.

(b) Meets ANSI/ISA Standard S82.03-1988.

(c)-D1 = DIN Single ended process cover with M10 bolting.

-D2 = DIN Double ended process cover with M10 bolting

-D3 = DIN Single ended process cover with 7/16 in bolting.

-D4 = DIN Double ended process cover with 7/16 in bolting.

-D5 = DIN Single ended process cover with 7/16 in 316 ss bolting.

-D6 = DIN Double ended process cover with 7/16 in 316 ss bolting.

-D7 = DIN Single ended process cover with 7/16 in 17-4 ss bolting.

-D8 = DIN Double ended process cover with 7/16 in 17-4 ss bolting.

(d)Limited to operating temperatures ranging from 0 to 60 °C (32 to 140°F)

(e)When Structure Codes 78/79 are used (pvdf inserts in the Hi and Lo side process covers), the maximum overrange is 2.1 MPa (300 psi) and temperature limits are -7 and +82°C (20 and 180°F).

— NOTE —

Static pressure zero shift for all calibrated spans can be eliminated by readjusting the zero output at nominal operating static pressure.

— CAUTION —

1. Exceeding the maximum overrange pressure can cause damage to the transmitter degrading its performance.
2. The transmitter could be nonfunctional after application of the proof pressure.

Output Signal

4 to 20 mA dc linear, 4 to 20 mA dc square root, or 1 to 5 VDC, software selectable, locally configurable using pushbuttons on the transmitter.

Zero and Span Adjustments

Adjustable at the transmitter using the local display. An optional external self-contained moisture sealed pushbutton assembly allows local resetting of zero without removing housing cover.

Field Wiring Reversal

Accidental reversal of field wiring will not damage the transmitter, provided the current is limited to 1 A or less by active current limiting or loop resistance. Sustained currents of 1 A will not damage the electronics module or sensor but could damage the terminal block assembly and external instruments in the loop.

Mounting Position

The transmitter can be mounted in any orientation. It can be supported by the process piping. It can also be mounted directly to a vertical or horizontal pipe or surface mounted using an optional mounting bracket. The housing can be rotated up to one full turn to any desired position for access to adjustments, display, or conduit connections. See “Positioning Housing” on page 13. The display can also be rotated in the housing to any of four different positions at 90° increments. See “Positioning Display” on page 13.

— NOTE —

Position effect zero shift for all calibrated spans can be eliminated by readjusting zero output after installation.

Adjustable Damping

The transmitter response time is normally 1.0 second or the electronically adjustable setting of 0.00 (none), 2, 4, or 8, seconds, whichever is greater, for a 90% recovery from an 80% input step as defined in ANSI/ISA S51.1.

Operative Limits

Influence	Operative Limits	
Sensor Body Temperature		
Silicone Fill Fluid	-46 and +121°C (-50 and +250°F)	
Fluorinert Fill Fluid	-29 and +121°C (-20 and +250°F)	
pvdf Inserts	-7 and +82°C (20 and 180°F)	
Electronics Temperature		
With LCD Display	-40 and +85°C (-40 and +185°F)(a)	
Relative Humidity	0 and 100%	
Supply Voltage	GPIDP-A	11.5 and 42 VDC(b)
	GPIDP-V	9 to 15.5 VDC
Output Load	GPIDP-A	0 and 1450 Ohms
	GPIDP-V	10 MegOhms
Mounting Position	No Limit	

(a) Display updates are slowed and readability decreased below temperatures of -20 °C (-4°F).

(b) 11 V dc with optional shorting block (AS code SB-11)

Sensor Fill Fluid

Silicone Oil (DC 200), or Fluorinert (FC-43).

Minimum Allowable Absolute Pressure vs. Process Temperature

With Silicone Fill Fluid

At full vacuum: Up to 121°C (250°F)

With Fluorinert Fill Fluid

Refer to Figure 2.

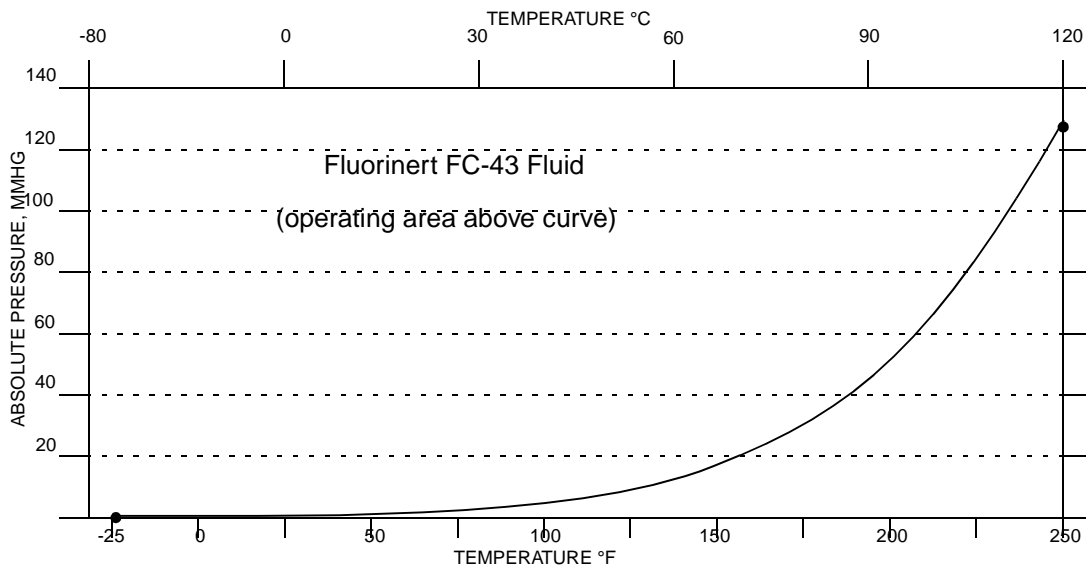

Figure 2. Minimum Allowable Absolute Pressure vs. Process Temperature with Fluorinert Fill Fluid

Powerup Time

Less than 2.0 seconds for output to reach approximately 3.5 mA, and then at the electronic damping rate to the final measured variable value.

Electrical Connections

Field wires enter through PG 13.5 or 1/2 NPT threaded entrances on either side of the electronics housing. Leads terminate under screw terminals and washers on the terminal block in the field terminal compartment. To maintain RFI/EMI, environmental, and explosionproof ratings, unused conduit connection must be plugged with metal plug (provided), inserted to five full turns.

Process Connections

GPIDP transmitters are connected to the process via a 1/4 NPT thread or any one of a number of optional process connectors.

Supply Current

Power supply must be capable of providing 22 mA current for the GPID-A and 3 mA current for the GPIDP-V. Ripple of up to 2 V pp (50/60/100/120 Hz) is tolerable, but instantaneous voltage must remain within specified range.

Electrical Ground Connections

The transmitter is equipped with an internal ground connection within the field wiring compartment and an external ground connection at the base of the electronics housing. To minimize galvanic corrosion, place the wire lead or terminal between the captive washer and loose washer on the external ground screw. If shielded cable is used, earth (ground) the shield at the field enclosure **only**. Do **not** ground the shield at the transmitter.

Test Points

The banana plug receptacles (designated CAL) can be used to check transmitter output of the GPIDP-A. Measurements should be 100 to 500 mV dc for 0 to 100% transmitter output. Refer to Figure 9.

HHT Terminals

As the top terminal is blocked, this transmitter does not communicate with the HHT, PC10, PC20, HART Communicator, or IFDC.

Approximate Mass

Without Process Connectors	3.5 kg (7.8 lb)
With Process Connectors	4.2 kg (9.2 lb)
With Optional 316 ss Housing	Add 1.1 kg (2.4 lb)

Process Wetted Materials

Diaphragm: 316L ss, Co-Ni-Cr, Hastelloy C, gold plated 316L ss, Monel, or tantalum
Covers and Process Connections: 316 ss, carbon steel, Hastelloy C, Monel, or pvdf inserts

Product Safety Specifications

DANGER

To prevent possible explosions and to maintain explosionproof, dust-ignitionproof protection, observe applicable wiring practices. Plug unused conduit opening with the provided metal pipe plug, which engages a minimum of five full threads.

WARNING

To maintain IEC IP66 and NEMA Type 4X protection, the unused conduit opening must be plugged. In addition, the threaded housing covers must be installed. Turn covers until O-ring contacts housing; then continue to hand tighten as much as possible (at least 1/4 turn).

2. Installation

The following material provides information and procedures for installing the GPIDP-A and GPIDP-V Differential Pressure Cell Transmitter.

—  **CAUTION** —

To avoid damage to the transmitter sensor, do not use any impact devices, such as an impact wrench or stamping device, on the transmitter.

— **NOTE** —

Use a suitable thread sealant on all connections.

Transmitter Mounting

The transmitter can be supported by the process piping as shown in Figure 3, or mounted to a vertical or horizontal pipe or surface using the optional mounting bracket shown in Figure 4.

— **NOTE** —

1. If the transmitter is not installed in the vertical position as shown in Figure 3 or Figure 4, readjust zero output to eliminate the position zero effect.
2. The transmitter should be mounted so that any moisture condensing or draining into the field wiring compartment can exit through one of the two threaded conduit connections.

Process-Mounted Transmitter

Figure 3 shows the transmitter mounted to and supported by the process piping.

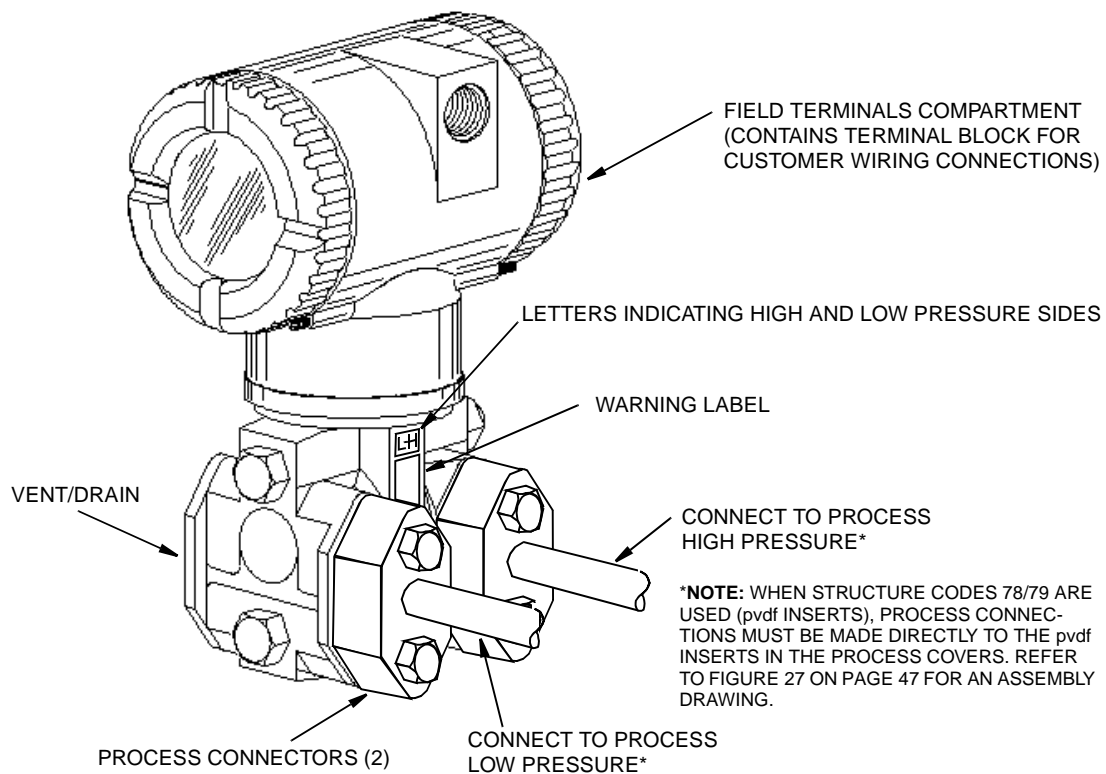
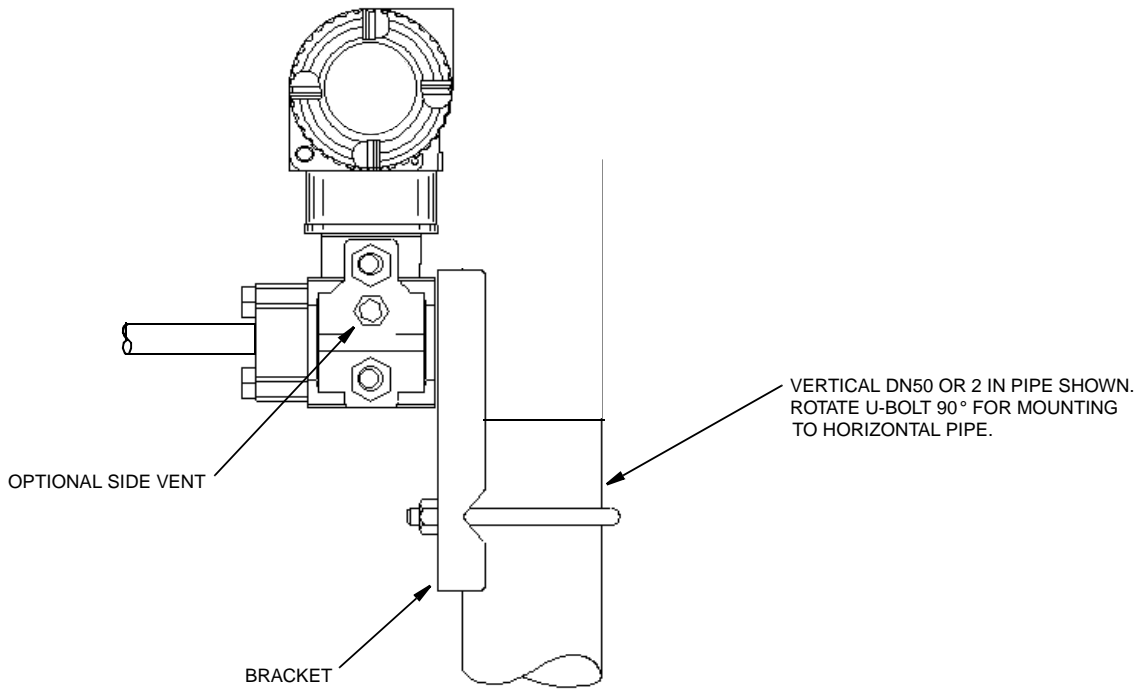

Figure 3. Process-Mounted Transmitter

Pipe- or Surface-Mounted Transmitter

To mount the transmitter to a pipe or surface, use the Optional Mounting Set (Model Code Option -M).

Referring to Figure 4, secure the mounting bracket to the transmitter using the two screws provided. Mount the transmitter with mounting bracket to a vertical or horizontal, DN 50 or 2-in pipe. To mount to a horizontal pipe, turn U-bolt 90° from the position shown in Figure 4. The mounting bracket can also be used for wall mounting by securing the bracket to a wall using the U-bolt mounting holes. Mounting kit extensions are available to allow 360° rotation of the topworks assembly. This provides better access to the rear vent/drain when the transmitter is mounted to a surface as shown in Figure 4.



MOUNTING TRANSMITTER TO A PIPE

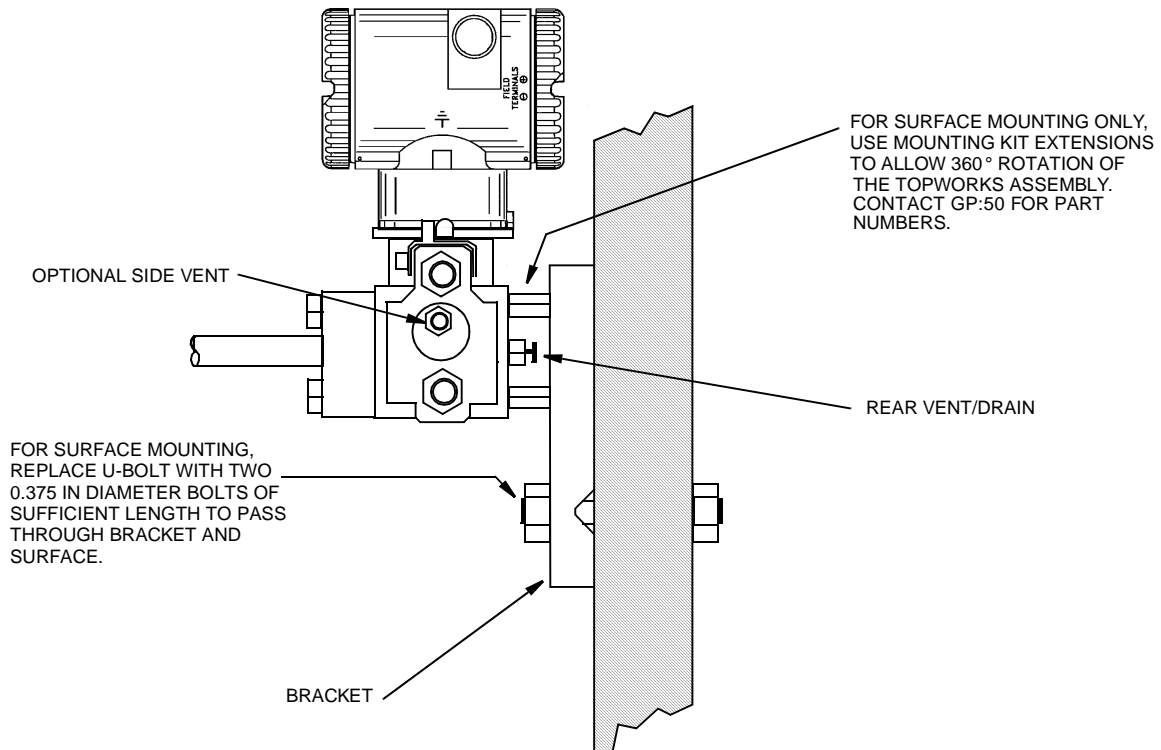

MOUNTING TRANSMITTER TO A SURFACE

Figure 4. Mounting Transmitter to a Pipe or Surface

Installation of Flow Measurement Piping

Figure 5 and Figure 6 show typical installations with horizontal and vertical process pipes.

The transmitters are shown below the level of the pressure connections at the pipe (usual arrangement, except for gas flow without a seal liquid), and with filling tees in the lines to the transmitter (for a seal liquid).

If the process fluid being measured must not come in contact with the transmitter, the transmitter lines must be filled with a suitable seal liquid (see procedure in next section). In such a case, the transmitter must be mounted below the level of the pressure connections at the pipe. With steam flow, the lines are filled with water to protect the transmitter from the hot steam. The seal liquid (or water) is added to the lines through the filling tees. To prevent unequal heads on the transmitter, the tees must be at the same elevation (as shown in Figure 5) and the transmitter must be mounted vertically (as shown). If a seal liquid is not required, elbows can be used in place of the tees.

Tighten drain plugs and optional vent screws to 20 N·m (15 lb·ft). Tighten the four process connector bolts to a torque of 61 N·m (45 lb·ft).

Note that the high and low pressure sides of the transmitter are identified by an L-H marking on the side of the sensor above the warning label as shown in Figure 3.

With medium-viscosity seal liquids and/or long transmitter lines, larger valve sizes should be used.

— **NOTE** —

1. With a **horizontal** line, pressure connections at the pipe should be at the **side** of the line. However, with **gas flow without** a seal liquid, connections should be at **top** of line.
 2. With a **vertical** line, flow should be **upwards**.
 3. For **liquid** or **steam** flow, the transmitter should be mounted **lower** than the pressure connections at the pipe.
 4. For **gas flow without** a seal liquid, the transmitter should be mounted **above** the pressure connections at the pipe; for **gas flow with** a seal liquid, the transmitter should be mounted **below** the pressure connections.
 5. GP:50 recommends the use of snubbers in installations prone to high levels of flow pulsations.
-

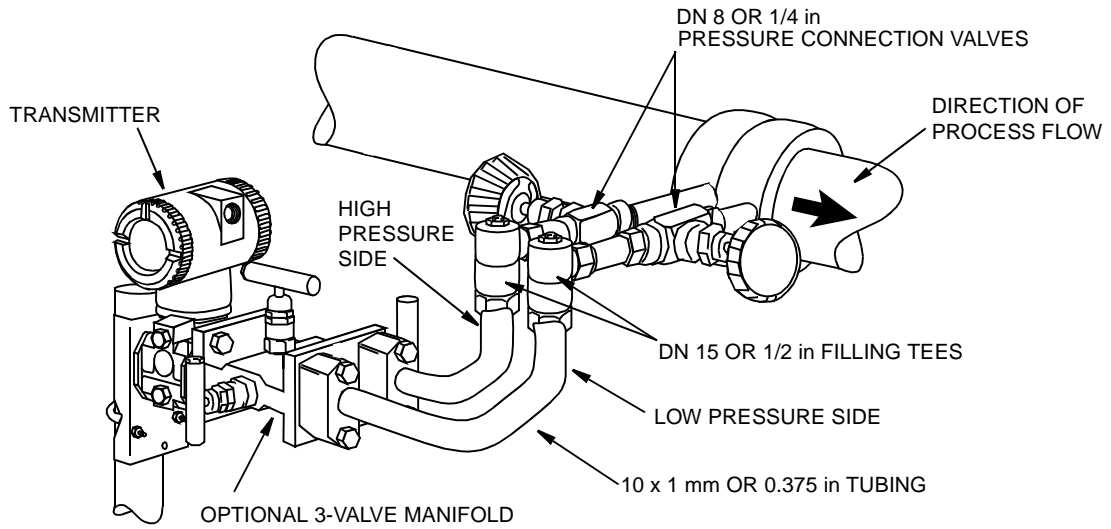

Figure 5. Example of Horizontal Process Line Installation

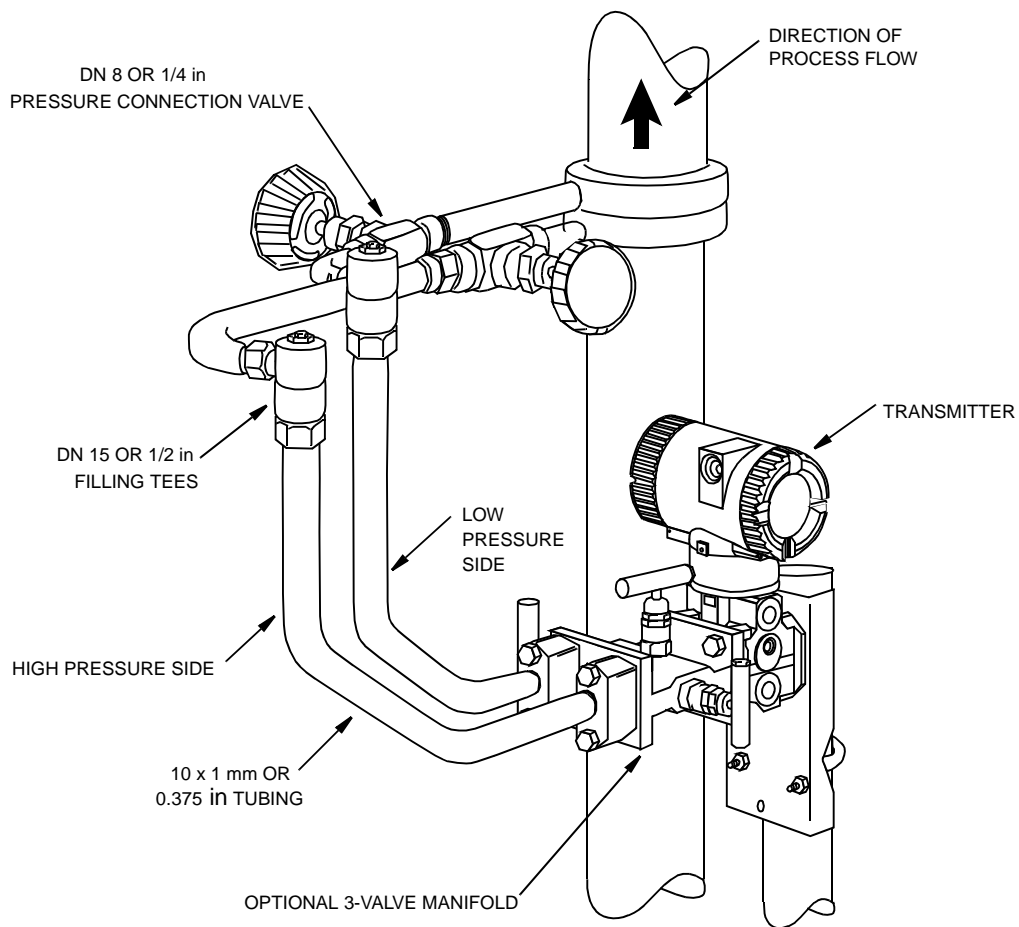

Figure 6. Example of Vertical Process Line Installation

Filling System with Seal Liquid

If the process fluid being measured must not come in contact with the transmitter, the transmitter lines must be filled with a suitable seal liquid. The procedure to do this is as follows:

1. If the transmitter is in service, follow the procedure for “Taking the Transmitter Out of Operation” on page 18.
2. Close both process shutoff valves.
3. Open all three valves on 3-Valve Manifold.
4. Partially open vent screws on transmitter until all air has been forced out of transmitter body and lines. Close vent screws.
5. Refill tee connections. Replace plugs and close bypass valve. Check for leaks.
6. Follow procedure for “Putting Transmitter into Operation” on page 18.

—⚠ CAUTION

To prevent loss of seal liquid and contamination of process fluid, never open both process shutoff valves and manifold shutoff valves if bypass valve is open.

Positioning Housing

The transmitter housing (topworks) can be rotated up to one full turn in the counterclockwise direction when viewed from above for optimum access to adjustments, display, or conduit connections.

—⚠ CAUTION

1. Do not rotate the housing more than one turn from the as received position. If there is doubt about the housing rotational position, turn fully clockwise and then back off no more than one full turn.
-

Positioning Display

The display can be rotated within the housing to any of four positions at 90° increments. To do this, refer to Figure 7 and perform the following:

1. Turn off power source to transmitter.
2. Screw in cover lock (if present) and remove the electronics compartment cover by rotating it counterclockwise.
3. Remove electronics module by unscrewing two screws closest to sides of transmitter and pulling out module.
4. If turning display 180°, turn and return module to housing by reversing Step 3.

5. If turning display 90° in either direction:
 - a. Remove the two (2) plastic buttons (plugs) by pushing them out from the backside of the module.

— **NOTE** —

Plastic buttons were not provided on some early versions of the electronics module.

- b. Unscrew the two (2) screws from the module and then rethread them back into the module at 90° from their original position.
 - c. Insert the two (2) plastic buttons into the two open screw holes in the module. (To order plastic buttons for earlier versions of the electronics modules or for replacement, consult with the Factory.)
 - d. Return the module to the housing by reversing Step 3.
6. Reinstall the cover onto the housing by rotating it clockwise until the O-ring contacts the housing; then continue to hand tighten as much as possible (at least 1/4 turn). If cover locks are present, align the serration in the cover with the lock and unscrew it until it extends into the cover serration to prevent unwanted cover rotation.
7. Restore power to transmitter.

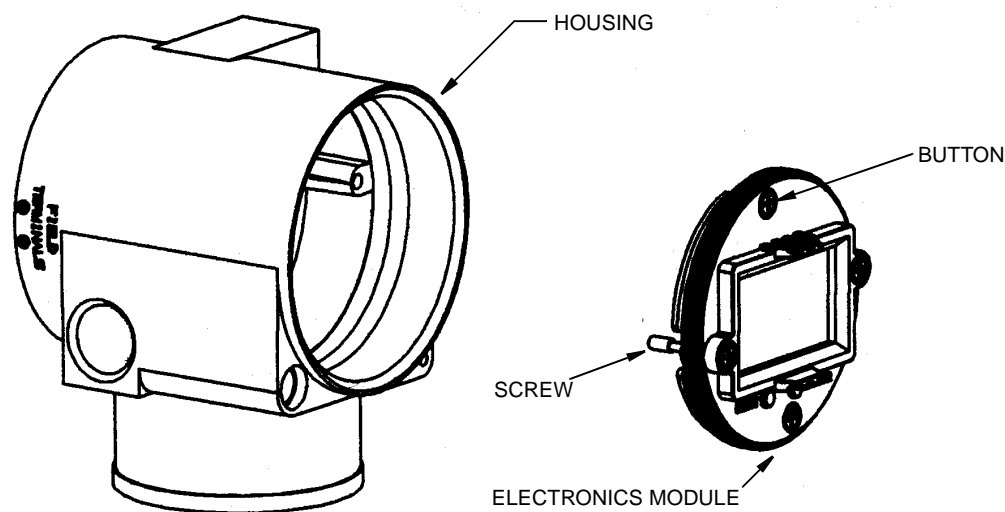

Figure 7. Positioning Display

Cover Locks

Electronic housing cover locks, shown in Figure 8, are provided as standard with certain agency certifications and as part of the Custody Transfer Lock and Seal option.

Transmitter Wiring for GPIDP-A (4-20 mA Output Signal)

The installation and wiring of your transmitter must conform to local code requirements.

NOTE

GP:50 recommends the use of transient/surge protection in installations prone to high levels of electrical transients and surges.

Accessing Transmitter Field Terminals

For access to the field terminals, thread the cover lock (if present) into the housing to clear the threaded cover and remove the cover from the field terminals compartment as shown in Figure 8. Note that the embossed letters **FIELD TERMINALS** identify the proper compartment. Identification of terminals is shown in Figure 9.

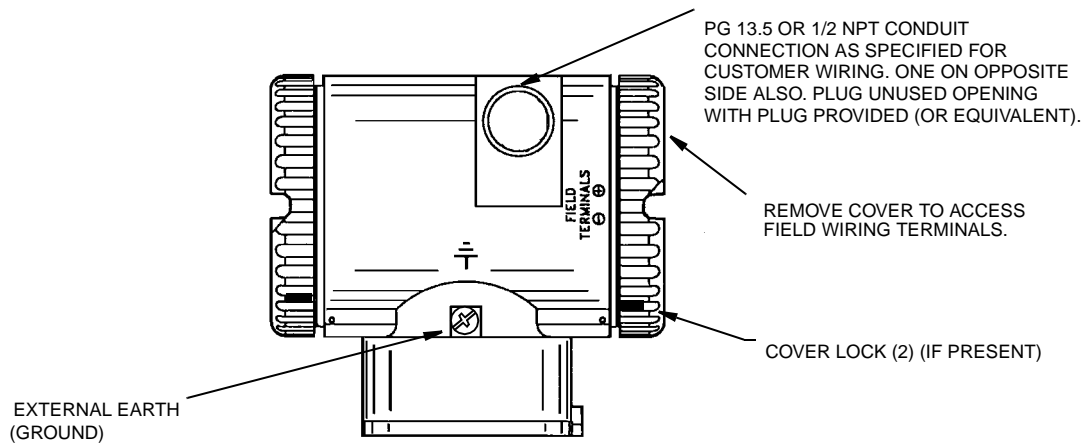

Figure 8. Accessing Field Terminals

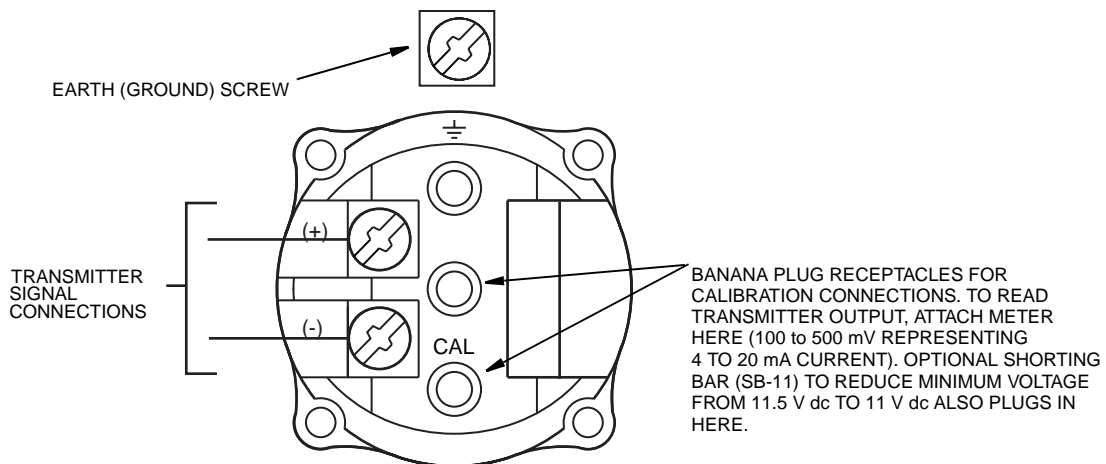

Figure 9. Identification of Field Terminals

Wiring the Transmitter to a Control Loop

When wiring your transmitter, the supply voltage and loop load must be within specified limits. The supply voltage vs. the output load relationship is shown in Figure 10. Any combination of supply voltage and loop load resistance in the shaded area can be used. To determine the loop load resistance (transmitter output load), add the series resistance of each component in the loop, excluding the transmitter. The power supply must be capable of supplying 22 mA of loop current.

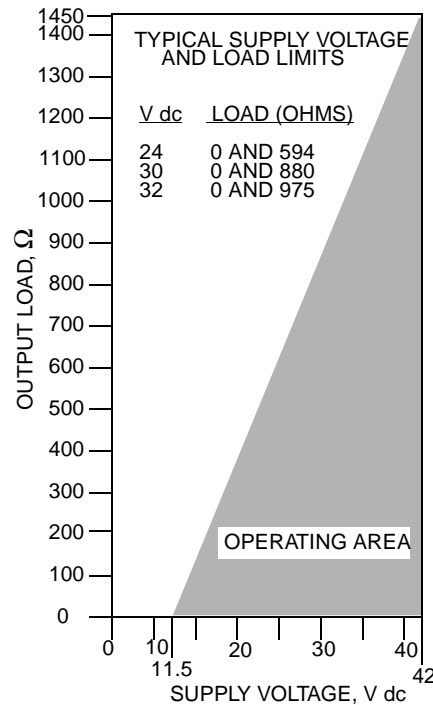

Figure 10. Supply Voltage and Loop Load

Examples:

1. For a loop load resistance of 860 Ω , the supply voltage can be any value from 30 to 42 V dc.
2. For a supply voltage of 24 V dc, the loop load resistance can be any value from zero to 565 Ω .

To wire one or more transmitters to a power supply, proceed with the following steps.

1. Screw in cover lock (if present) and remove the field terminals compartment cover by rotating it counterclockwise.
2. Run signal wires (0.50 mm² or 20 AWG, typical) through one of the transmitter conduit connections as shown in Figure 11. Use twisted single pair to protect the 4 to 20mA output from electrical noise. Screened (shielded) cable may be required in some locations.

NOTE

Do not run transmitter wires in same conduit as main (ac power) wires.

2. Installation

3. If shielded cable is used, earth (ground) the shield at the power supply only. Do not ground the shield at the transmitter. Cut and/or tape the shield so it cannot contact the metal housing.
4. Plug unused conduit connection with the PG 13.5 or 1/2 NPT metal plug provided (or equivalent). To maintain specified explosionproof and dust-ignitionproof protection, plug must engage a **minimum** of five full threads. Thread sealant is recommended.
5. Connect an earth (ground) wire to the earth terminal in accordance with local practice.

—⚠ CAUTION —

If the signal circuit must be earthed (grounded), it is preferable to do so at the negative terminal of the dc power supply. To avoid errors resulting from earth loops or the possibility of short-circuiting groups of instruments in a loop, there should be only one earth in a loop.

6. Connect the power supply and receiver loop wires to the “+” and “-” terminal connections shown in Figure 9.
7. Connect receivers (such as controllers, recorders, indicators) in series with power supply and transmitter as shown in Figure 11.
8. Reinstall the cover onto the housing by rotating it clockwise until the O-ring contacts the housing. Then continue to hand tighten as much as possible (at least 1/4 turn). If cover locks are present, align the serration in the cover with the lock and unscrew it until it extends into the cover serration to prevent unwanted cover rotation.
9. If wiring additional transmitters to the same power supply, repeat Steps 1 through 8 for each additional transmitter. The setup with multiple transmitters connected to a single power supply is shown in Figure 12.

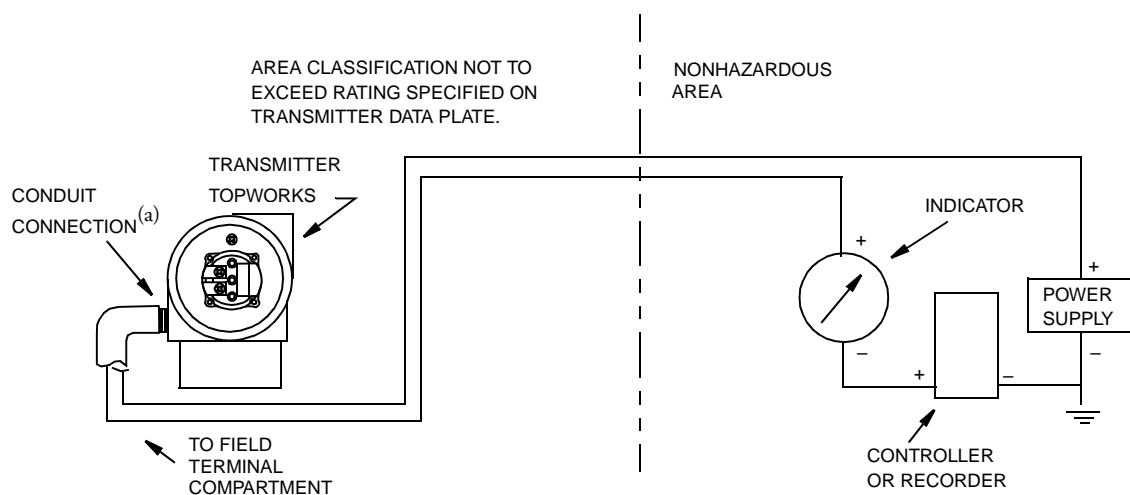

(a) RUN CONDUIT DOWN TO AVOID MOISTURE BUILDUP IN TERMINALS COMPARTMENT.

Figure 11. Loop Wiring

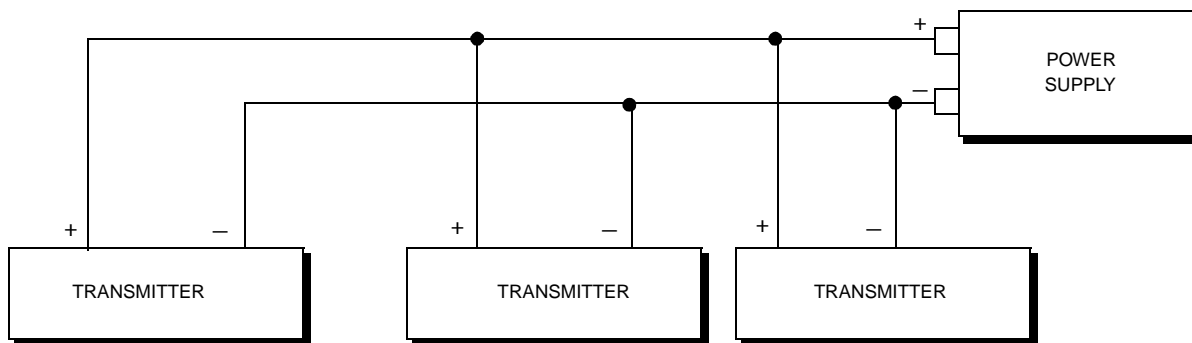

Figure 12. Wiring Several Transmitters to a Common Power Supply

Putting Transmitter into Operation

The following procedure explains how to sequence the valves in your flow measurement piping or optional bypass manifold to ensure that your transmitter is not overranged and that seal liquid is not lost. Refer to Figure 5 or Figure 6.

— **NOTE** —

Procedure assumes that Process shutoff valves are open.

1. Make sure that both upstream and downstream manifold valves are closed.
2. Make sure that bypass valve is open.
3. Slowly open upstream manifold valve.
4. Close bypass valve.
5. Slowly open downstream manifold valve.

Taking the Transmitter Out of Operation

The following procedure explains how to sequence the valves in your flow measurement piping or optional bypass manifold to ensure that your transmitter is not overranged and that seal liquid is not lost. Refer to Figure 5 or Figure 6.

— **NOTE** —

Procedure assumes that Process shutoff valves are open.

1. Close downstream manifold valve.
2. Close upstream manifold valve.
3. Open bypass valve.
4. Carefully open the vent screw to release any residual pressure before disconnecting lines.

—  **WARNING** —

When venting pressure from the transmitter, wear suitable protective equipment to prevent possible injury from process material, temperature, or pressure.

Transmitter Wiring for GPIDP-V (1-5 VDC Output Signal)

The field terminals on a transmitter with a 1 to 5 V dc output signal are shown in Figure 13.

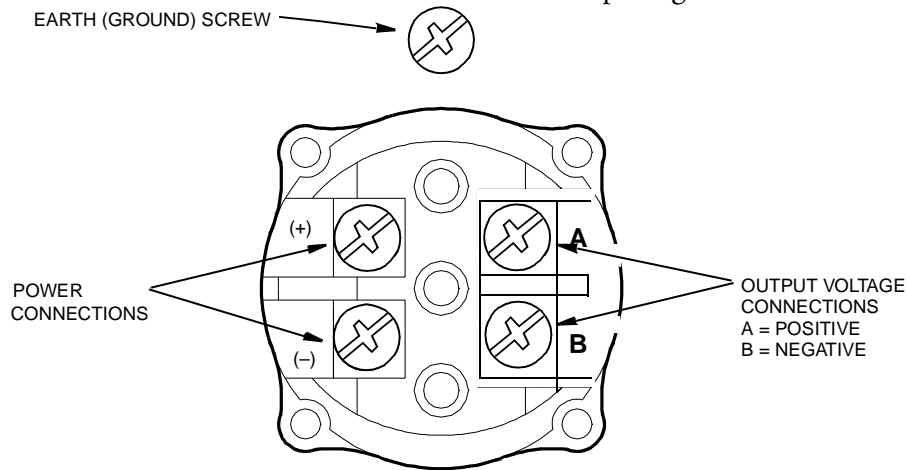

Figure 13. Identification of Field Terminals

The transmitter is equipped with an internal ground connection within the field wiring compartment and an external ground connection at the base of the electronics housing. To minimize galvanic corrosion, place the wire lead or terminal between the captive washer and loose washer on the external ground screw. If shielded cable is used, earth (ground) the shield at the field enclosure **only**. Do **not** ground the shield at the transmitter.

Power Supply Voltage and Current

The power supply voltage across the transmitter input terminals can be any value between 9 and 15.5 V dc and the power supply must be capable of supplying 3 mA of current under all conditions. Verify that the power supply loop load resistance and source impedance allow at least 9 V dc across the transmitter input terminals with a current draw of 3 mA.

Output Load

The receiver input impedance can be any value between 1 and 10 M Ω

Three or Four Wire Connections

The transmitter is supplied with a four-wire terminal block with the two negative terminals (- and B) electrically connected internally. This means that the transmitter can be wired with either three wires for wiring economy or four wires for maximum accuracy.

For relatively short wiring runs having low resistance, three-wire connections as shown in Figure 14 can be used to minimize wiring costs. However, a voltage drop in the common lead carrying the power supply current causes an error in the 1 to 5 V dc signal.

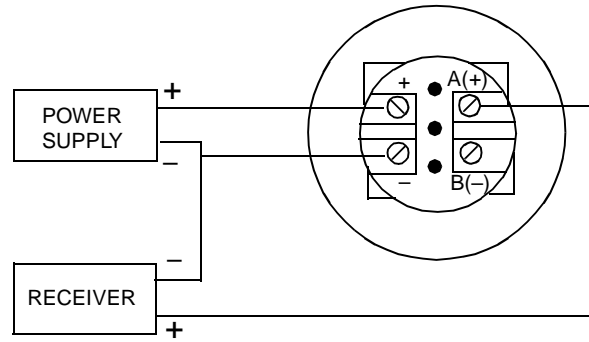

Figure 14. Three-wire Connection

For wiring runs with high resistance (due to long lengths or other reasons) or for maximum accuracy, a four-wire connection as shown in Figure 15 can be used to provide input-output isolation. With four-wire configuration, voltage drop in the power supply loop does not affect measurement accuracy.

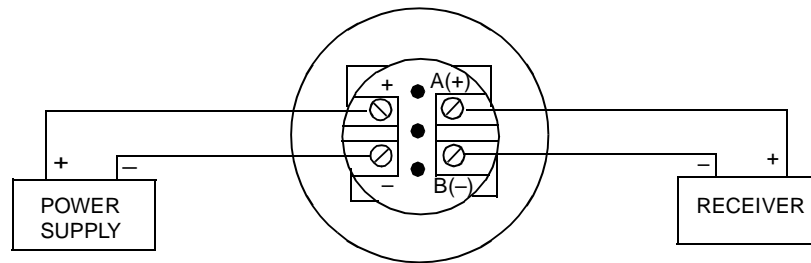

Figure 15. Four-wire Connection

To wire a transmitter, proceed with the following steps.

1. Screw in cover lock (if present) and remove the field terminals compartment cover by rotating it counterclockwise.
2. Run the supply voltage and output wires (0.50 mm² or 20 AWG, typical) through one of the transmitter conduit connections as shown in Figure 8. If four-wire connection is used, use twisted single pair on the output side to protect the 1 to 5 V dc output from electrical noise.

— NOTE

Do not run transmitter wires in same conduit as mains (ac power) wires.

3. If shielded cable is used, earth (ground) the shield at the receiver **only**. Do **not** ground the shield at the transmitter. Cut and/or tape the shield so it cannot contact the metal housing.
4. Plug unused conduit connection with the PG 13.5 or 1/2 NPT metal plug provided (or equivalent). To maintain specified explosionproof and dust-ignitionproof protection, plug must engage a **minimum** of five full threads. Thread sealant is recommended.

5. Connect an earth (ground) wire to the earth terminal in accordance with local practice.

— **⚠ CAUTION** —

If the output circuit must be earthed (grounded), it is preferable to do so at the negative terminal of the receiver. To avoid errors resulting from earth loops or the possibility of short-circuiting groups of instruments in a loop, there should be only one earth in a loop.

6. Connect the power supply and receivers (such as controllers, recorders, indicators) as shown in Figure 14 or Figure 15. Typical loop wiring is shown in Figure 16.
7. Reinstall the cover onto the housing by rotating it clockwise until the O-ring contacts the housing. Then continue to hand tighten as much as possible (at least 1/4 turn). If cover locks are present, align the serration in the cover with the lock and unscrew it until it extends into the cover serration to prevent unwanted cover rotation.
8. If wiring additional transmitters to the same power supply, repeat Steps 1 through 7 for each additional transmitter. The setup with multiple transmitters connected to a single power supply is shown in Figure 17.
9. For installations with long runs, GP:50 recommends using two twisted pair with one pair connected to the power supply terminals and one pair connected to the output terminals. The two twisted pair can be in individual shields or a common shield with the shield connected to the receiver. The shield must **not** be connected to the transmitter.

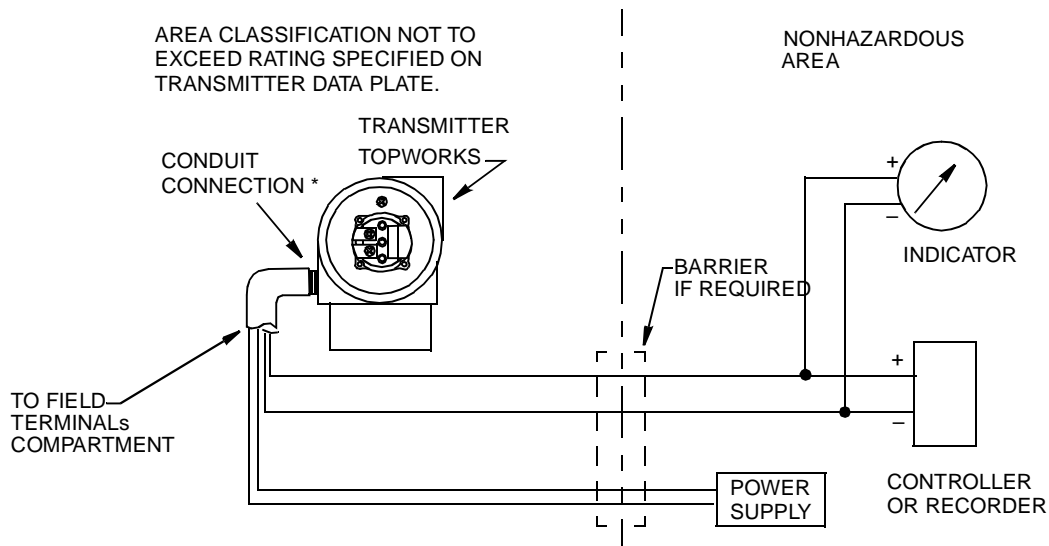

* Run conduit down to avoid moisture buildup in field terminals compartment.

Figure 16. Loop Wiring (four-wire connection shown)

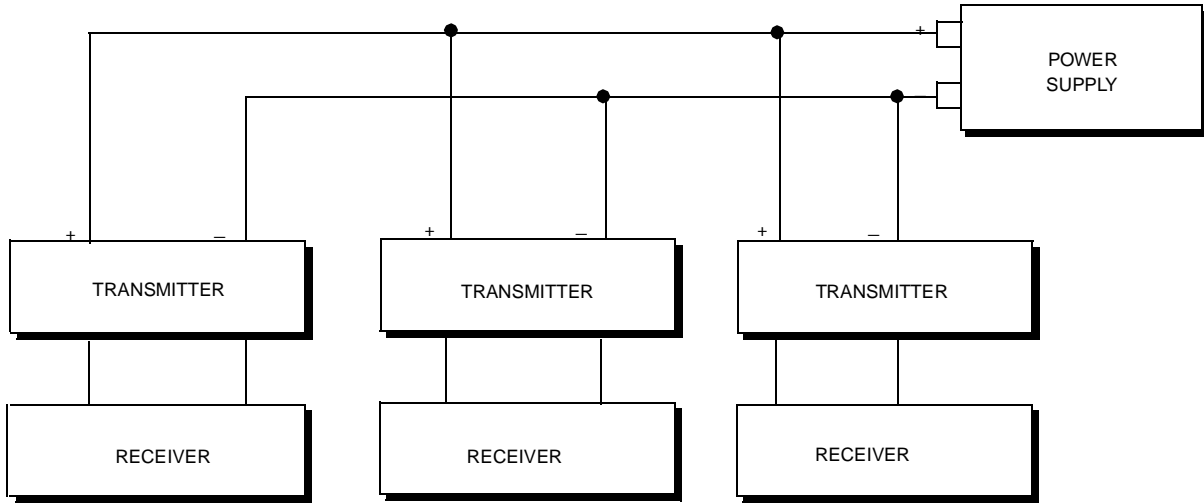

NOTE: Four wire connection shown

Figure 17. Wiring Several Transmitters to a Common Power Supply GPIDP-V

Putting Transmitter into Operation

The following procedure explains how to sequence the valves in your flow measurement piping or optional bypass manifold to ensure that your transmitter is not overranged and that seal liquid is not lost. Refer to Figure 5 or Figure 6.

— **NOTE** —

Procedure assumes that Process shutoff valves are open.

1. Make sure that both upstream and downstream manifold valves are closed.
2. Make sure that bypass valve is open.
3. Slowly open upstream manifold valve.
4. Close bypass valve.
5. Slowly open downstream manifold valve.

Taking the Transmitter Out of Operation

The following procedure explains how to sequence the valves in your flow measurement piping or optional bypass manifold to ensure that your transmitter is not overranged and that seal liquid is not lost. Refer to Figure 5 or Figure 6.

— **NOTE** —

Procedure assumes that Process shutoff valves are open.

1. Close downstream manifold valve.
2. Close upstream manifold valve.
3. Open bypass valve.
4. Carefully open the vent screw to release any residual pressure before disconnecting lines.

—  **WARNING** —

When venting pressure from the transmitter, wear suitable protective equipment to prevent possible injury from process material, temperature, or pressure.

3. Calibration and Configuration

—  **CAUTION** —

Anytime Calibration (**CALIB**) or Configuration (**CONFIG**) mode is entered, the transmitter output is automatically set to 1 volt until **Cancel** or **Save** is selected and the transmitter comes back online. Make sure that the control loop is in **manual** before selecting **CALIB** or **CONFIG**.

— **NOTE** —

1. For best results in applications where high accuracy is required, rezero the transmitter output once it has stabilized at the final operating temperature.
 2. Zero shifts resulting from position effects and/or static pressure effects can be eliminated by rezeroing the transmitter output.
 3. When checking the zero reading of a transmitter operating in the square root mode, return the output to the linear mode. This will eliminate an apparent instability in the output signal. Return the transmitter output to the square root mode after the zero check is complete.
 4. After calibrating transmitters operating with a 4 to 20 mA output signal, check the underrange and overrange output values to ensure that they extend beyond 4 and 20 mA respectively.
-

Calibration Setup

The following sections show setups for field or bench calibration. Use test equipment that is at least three times as accurate as the desired accuracy of the transmitter. Calibration is performed by simulating the process differential pressure. This is done by applying a pressure, equal to the differential pressure, to one side of the transmitter and then venting the other side of the transmitter.

— **NOTE** —

The GPIDP-A and GPIDP-V transmitters can be reranged to a new calibrated range without application of pressure. See EGU LRV and EGU URV in Figure 24.

Field Calibration Setup

Field calibration is performed without disconnecting the process piping. In order to do this, you must have bypass and shutoff valves between the process and the transmitter and one of the following:

Access to the process connections on the nonprocess side of the transmitter, or,

The optional vent screw in the side of the process covers.

If the transmitter is to be removed from the process for calibration, refer to the “Bench Calibration Setup” procedure.

For field calibration, an adjustable air supply and a pressure measuring device are required. For example, a dead weight tester or an adjustable clean air supply and pressure gauge can be used. The pressure source can be connected to the transmitter process connection with pipe fittings or it can be connected to the vent screw assembly using a calibration screw. The calibration screw has a Polyflo fitting and can be used for pressures up to 700 kPa (100 psi). It is available from GP:50.

— **NOTE** —

For high differential calibrations above 700 kPa (100 psi), calibration screw B0142NA can be used along with high pressure Swagelok fittings having a rating of 21 MPa (3000 psi), or more.

To set up the equipment, refer to Figure 18 and use the following procedure.

1. If the transmitter is in operation, follow the procedure on “Taking the Transmitter Out of Operation” on page 23.

—  **CAUTION** —

With liquid service, drain both sides of transmitter to avoid calibration errors.

2. If a calibration screw is being used, remove the vent screw and replace it with the calibration screw. Connect the pressure source to the calibration screw using 6 x 1 mm or 0.250 inch tubing.
If a calibration screw is **not** being used, remove the entire vent screw assembly or drain plug (as applicable) from the high pressure side of the transmitter. Connect calibration tubing using a suitable thread sealant.
3. Close the bypass valve opened in Step 1.
4. Complete the setup shown in Figure 12.

— **NOTE** —

For vacuum applications, connect the calibrating pressure source to the low pressure side of the transmitter.

5. If calibrating the 4 to 20 mA output signal, also connect equipment as shown in Figure 19.

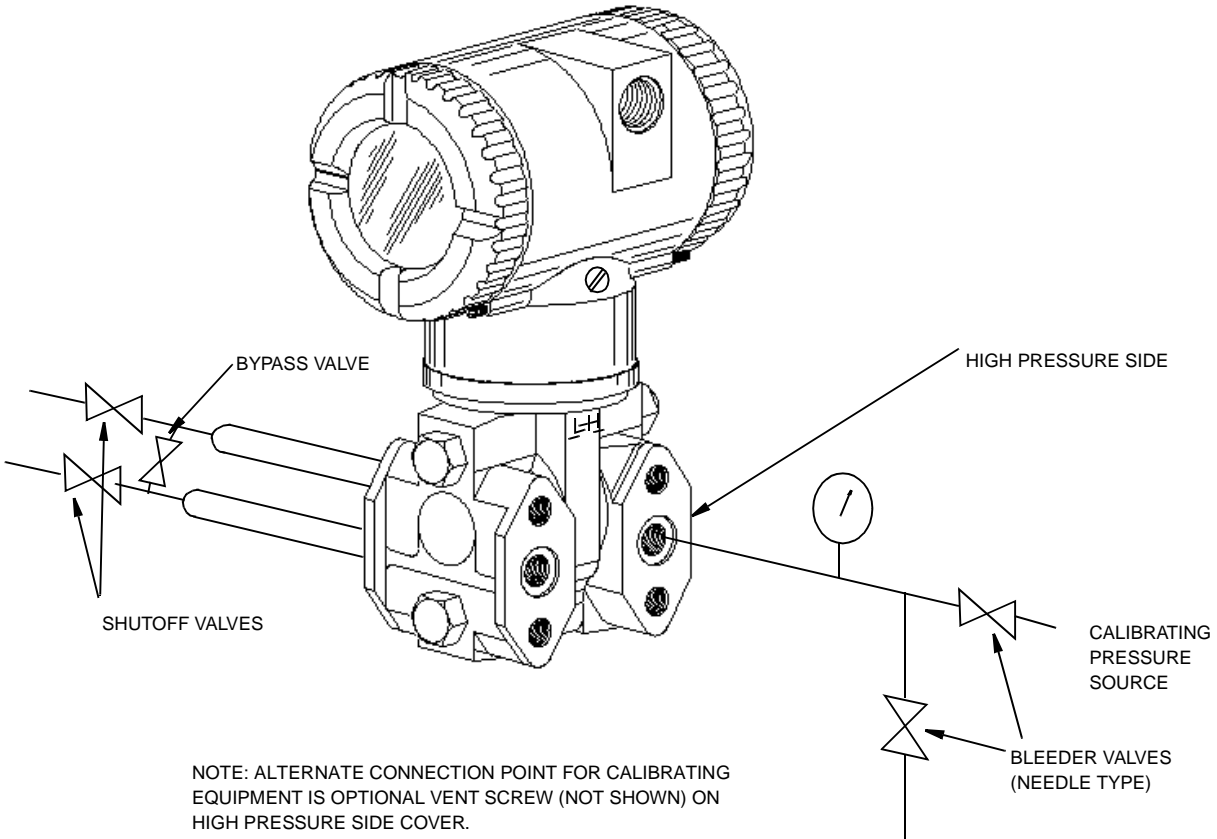
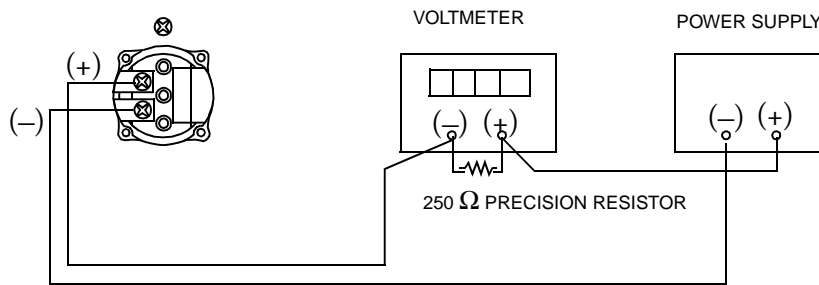

Figure 18. Field Calibration Setup



RESISTOR: 250 Ω, ±0.01%, 1 W MINIMUM (PART NO. E0309GY)
 POWER SUPPLY: REFER TO FIGURE 10
 DIGITAL VOLTMETER: READINGS FROM 1.000 TO 5.000 V dc

Figure 19. Calibration Setup of Electronic Equipment (GPIDP-A)

Bench Calibration Setup

The bench calibration setup requires disconnecting the process piping. For calibration setup without disconnecting the process piping, refer to the “Field Calibration Setup” procedure.

The input setup is shown in Figure 20. Connect the input piping to the high pressure side of the transmitter as shown. Vent the low pressure side of the transmitter.

NOTE

For vacuum applications, connect the calibrating pressure source to the low pressure side of the transmitter.

Also connect electronic equipment as shown in Figure 19

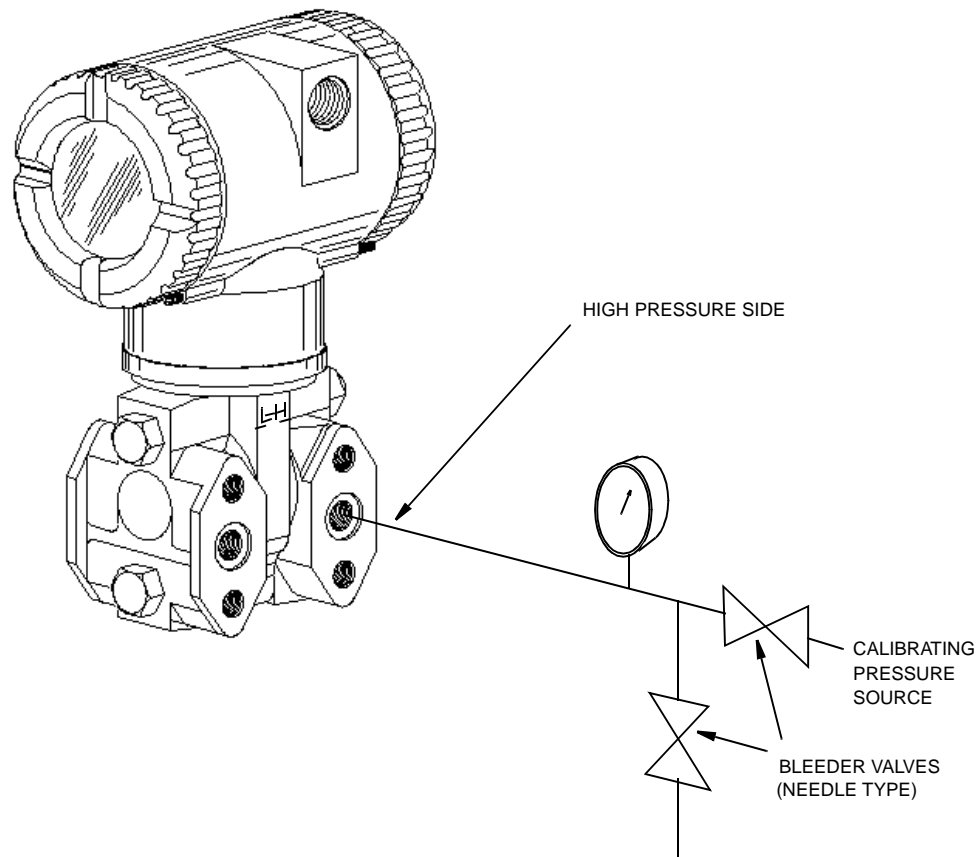

Figure 20. Bench Calibration Setup

General Calibration Notes

1. Each transmitter is factory characterized over its full rated differential pressure range. One benefit of this process is that every transmitter can measure any applied differential pressure within its range limits regardless of the calibrated range. The applied differential pressure is measured and converted into an internal digital value. This digital value of differential pressure is always available whether the transmitter is calibrated or not. Calibration assures that the transmitter rated accuracy is achieved over the calibrated range.
2. The internal digital value of differential pressure can be displayed on the local display, and converted to a 4 to 20 mA or 1 to 5 VDC analog output signal.

3. Each transmitter is factory calibrated to either a specified or a default calibrated range. This calibration optimizes the accuracy of the internal digital value of differential pressure over that range. If no range is specified, the default range is zero to the sensor upper range limit (URL).
4. There is an independent trim on the digital-to-analog conversion stage. This trim allows for slight adjustment of the 4 and 20 mA or 1 and 5 VDC outputs. This compensates for any slight difference that exists between the transmitter output and an external reference device which is measuring the output.
 - ◆ The trim does not affect the calibration or the reranging of the transmitter and does not affect the internal digital value of pressure or the transmission or display of measured pressure.
 - ◆ The trim can be done with or without pressure applied to the transmitter.

Notes for Electronic Version -A and -V

The transmitter data base has configurable values for both Lower Range value (LRV) and upper range value (URV). These stored values are used for two functions; defining the calibrated range and reranging without pressure.

1. Defining the Calibrated Range
 - ◆ When either **CAL LRV** or **CAL URV** is initiated from the pushbuttons, the transmitter expects that the differential pressure applied at the time the button is pressed is equal to the LRV or URV value respectively.
 - ◆ This function trims the internal digital value of differential pressure; that is, it performs a calibration based on the application of accurate differential pressures equal to the values entered for LRV and URV in the transmitter database.
 - ◆ This function also sets the 4 and 20 mA (1 and 5 VDC for GPIDP-V) output points; that is, the 4 and 20 mA (1 and 5 VDC for GPIDP-V) points correspond to the values of LRV and URV in the database.
 - ◆ If the transmitter is configured for reverse range, the 20 and 4 mA (5 and 1 VDC for GPIDP-V) points correspond to the LRV and URV respectively.
2. Reranging Without the Application of Pressure
 - ◆ Since the transmitter continually determines an internal digital value of the measured differential pressure from the lower range limit (LRL) to the upper range limit (URL), the 4 and 20 mA (1 and 5 VDC for GPIDP-V) output points can be assigned to any range values (within the span and range limits) without application of pressure.
 - ◆ The reranging function is accomplished by entering new database values for LRV and URV.
 - ◆ Reranging does not affect the calibration of the transmitter; that is, the optimization of the internal digital value of differential pressure over a specific calibrated range.
 - ◆ If the reranged LRV and URV are not within the calibrated range, the measured values may not be as accurate as when they are within the calibrated range.

3. LCD Indicator

- ◆ The display can show any measured differential pressure in selected units regardless of the calibrated range and the values of LRV and URV (within the limits of the transmitter and display). The display can also be 0 to 100 percent.
- ◆ If the measured differential pressure is outside the range established by the LRV and URV values in the database, the display shows the measurement but also continually blinks to indicate that the measurement is out of range. The current signal is saturated at either the low or high overrange limit respectively but the display continually shows the pressure.
- ◆ Custom flow units for display, including 0 to 100 percent, are used when the transmitter is in square root mode.

4. Zeroing the Transmitter

- ◆ Zeroing does not affect the span.
- ◆ When the transmitter is zeroed to compensate for installed position effect, the transmitter may have either LRV differential pressure applied (**CAL LRV**) or zero differential pressure applied (**CAL AT0**). If using a zero-based range, either method produces the same result. However, if the range is not zero-based, it is advantageous to have both methods available.

For example, consider a differential pressure transmitter having a range of 50 to 100 psig. If it is not feasible to vent the transmitter to atmosphere for zeroing (or to bypass the high and low sides for zeroing), it may be zeroed while the LRV differential pressure of 50 psi is applied by using the **CAL LRV** function. On the other hand, if the transmitter has been installed but there is no pressure in the process line yet (or the high and low sides can be connected by a bypass valve), it can be zeroed while open to atmosphere (or bypassed) by using the **CAL AT0** function.

a. Zeroing with LRV Pressure Applied (**CAL LRV**)

- ◆ Before using this zeroing function, apply a differential pressure to the transmitter equal to the value of LRV stored in the transmitter database.
- ◆ When zeroing the transmitter, the internal digital value of differential pressure is trimmed to be equal to the value of LRV stored in the database and the mA (VDC for GPIDP-V) output set to 4 mA (1 VDC for GPIDP-V).
- ◆ If zeroing is done when the applied differential pressure is different from the LRV value in the database, the internal digital value of differential pressure is biased by the difference in the values but the output is still set at 4 mA (1 VDC for GPIDP-V).
- ◆ The **CAL LRV** (and **CAL URV**) function should be used when calibrating a transmitter for a specific range with known input differential pressures applied for the LRV and URV.

b. Zeroing with Zero Pressure Applied (**CAL AT0**)

- ◆ Make sure that the applied differential pressure is at zero. This means venting the transmitter to atmosphere.

- ◆ When zeroing the transmitter, the internal digital value of the differential pressure is trimmed to be equal to zero and the mA output (VDC for GPIDP-V) set to an appropriate value such that the mA output (VDC for GPIDP-V) is a nominal 4 mA (1 VDC for GPIDP-V) when the LRV pressure is applied later.

Calibration and Configuration Using the Local Display

The local display, as shown in Figure 21, has two lines of information. The upper line is a 5-digit numeric display (4-digit when a minus sign is used); the lower line is an 7-digit alphanumeric display. The display provides local indication of measurement information and a means for performing calibration and configuration, and testing the display via a 2-button (**Next** and **Enter**) keypad. You can access these operations by means of a multi-level menu system. Entry to the Mode Select menu is made (from normal operating mode) by pressing the **Next** button. You can exit this menu, restore your prior calibration or configuration, and return to the normal operating mode at any time by going to **Cancel** and pressing the **Enter** button.

NOTE

During calibration or configuration, a single change may affect several parameters. For example, changing from linear to square root mode also changes the engineering units (EGU) to **Percent** by default. For this reason, if an entry is **Entered** in error, re-examine the entire data base or use the **Cancel** feature to restore the transmitter to its starting configuration and begin again.

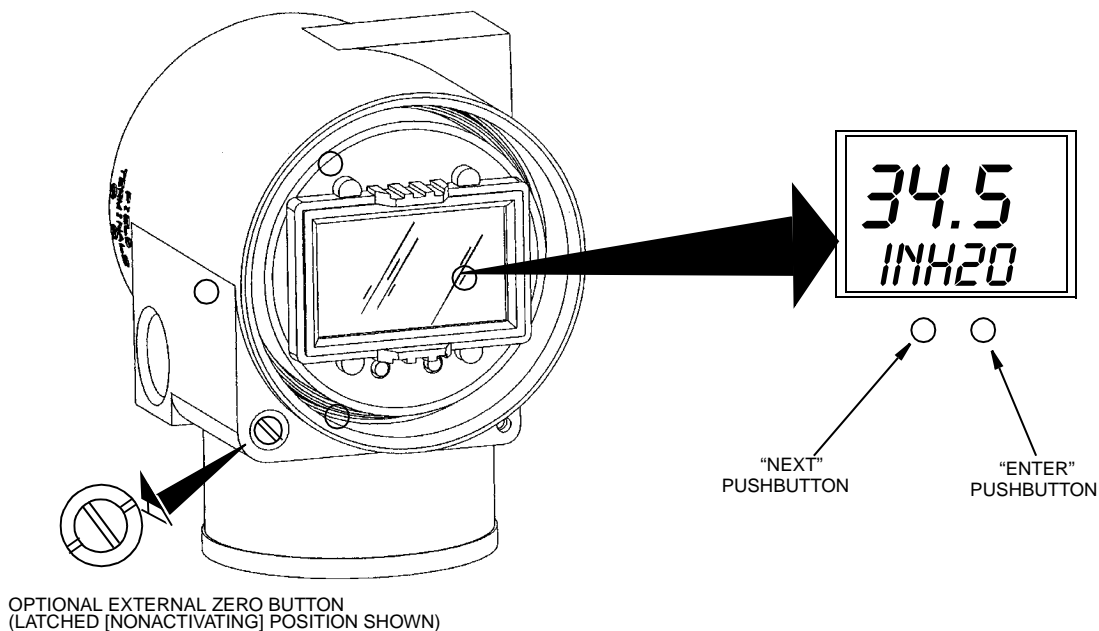

Figure 21. Local Display Module

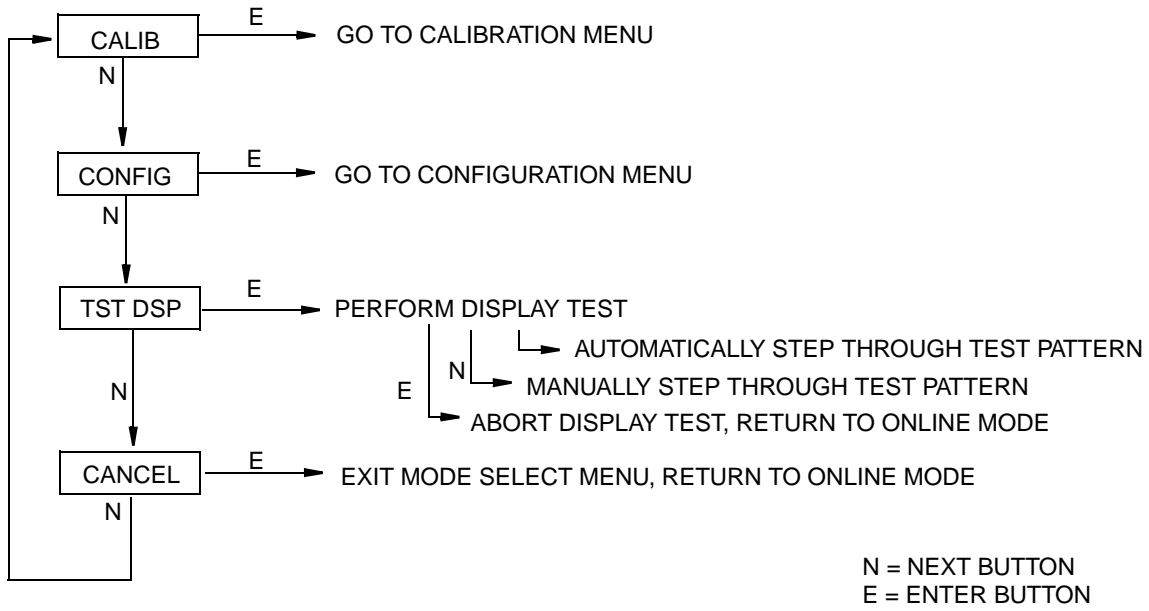

Figure 22. Top Level Structure Diagram

Calibration

To access the Calibration mode (from normal operating mode), press the **Next** button. The display reads **CALIB**, the first item on the menu. Acknowledge your choice of this selection by pressing the **Enter** button. The display will show the first item in the Calibration menu. You can then calibrate the items shown in Table 2.

Table 2. Calibration Menu

(For GPIDP-V, substitute 1 volt for 4 mA and 5 volts for 20 mA.)

Item □	Description
CAL AT0	Calibrate with zero pressure.
CAL LRV	Calibrate with pressure at 0% of transmitter range (LRV)
CAL URV	Calibrate with pressure at 100% of transmitter range (URV)
ADJ 4MA	Adjust nominal 4 mA output
ADJ 20MA	Adjust nominal 20 mA output
ADJ 4MA causes the following four submenus	
A 4mA▲▲	Increase 4 mA output by large step
A 4mA▽▽	Decrease 4 mA output by large step
A 4mA▲	Increase 4 mA output by small step
A 4mA▽	Decrease 4 mA output by small step
ADJ 20MA causes the following four submenus	
A 20mA▲▲	Increase 20 mA output by large step
A 20mA▽▽	Decrease 20 mA output by large step
A 20mA▲	Increase 20 mA output by small step
A 20mA▽	Decrease 20 mA output by small step

For GPIDP-V, substitute 1 volt for 4 mA and 5 volts for 20 mA.

— NOTE —

1. It is not necessary to use the **ADJ4MA** or **ADJ20MA** menu selections unless there is a plant requirement to make the 4 and 20 mA output values exactly match readings on certain plant calibration equipment and the “zero” and “span” operations done result in a small but unacceptable difference between the transmitter mA output and the test equipment mA readout values.
2. The GPIDP-A transmitter can be reranged without the application of pressure. See **EGU LRV** and **EGU URV** in Figure 24.

Proceed to calibrate your transmitter by using the **Next** key to select your item and the **Enter** key to specify your selection per Figure 23. At any point in the calibration you may **Cancel**, restore your prior calibration and return to the online mode or Save your new calibration.

GPIDPA and GPIDP-V Calibration

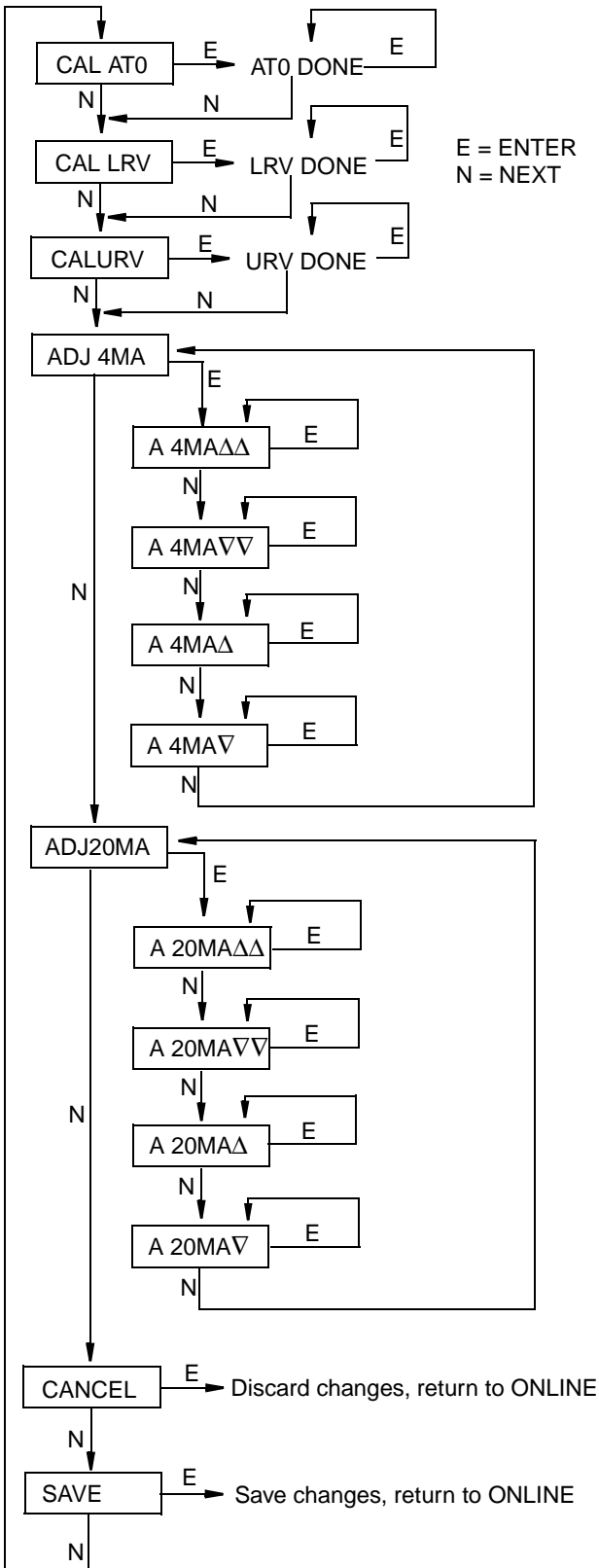

CAL AT0: To set or reset the zero point at zero differential pressure, apply zero differential pressure to the transmitter and, at display of **CAL AT0**, press **Enter**. This can be done whether LRV is zero or not. Completion is indicated by the display **AT0 DONE**.

CAL LRV: To set or reset 0% of range input, apply differential pressure to the transmitter equal to the Lower Range Value (LRV) in the transmitter data base and, at display of **CAL LRV**, press **Enter**. Completion is indicated by the display **LRV DONE**.

CAL URV: To set or reset 100% of range input, apply differential pressure to the transmitter equal to the Upper Range Value (URV) in the transmitter data base and, at display of **CAL URV**, press **Enter**. Completion is indicated by the display **URV DONE**.

ADJ4mA: If you configured your transmitter operating mode as 4 to 20 mA, you can adjust the 4 mA output by going to **ADJ4mA** using the **Next** button and press **Enter**. This menu item is bypassed if you had configured your transmitter operating mode as digital.

To increase the 4 mA output by a large (0.025 mA) step, press **Enter** at the display **A 4mAΔΔ**. To decrease it by a large step, go to the display **A 4mA∇∇** by pressing the **NEXT** button and then **Enter**. To increase it by a small (0.001 mA) step, go to the display **A 4mAΔ** with the **Next** button and then press **Enter**. To decrease it by a small step, go to the display **A 4mA∇** with the **Next** button and then press **Enter**.

ADJ20mA: Similar to **ADJ4mA**.

Figure 23. Calibration Structure Diagram

Zero Adjustment Using External Zero Button

An optional external zero adjustment mechanism in the electronics housing (see Figure 21) allows local “rezeroing” of the transmitter output without having to remove the electronics compartment cover. The mechanism is magnetically activated through the housing wall to prevent moisture from entering the enclosure. Zeroing is accomplished when the external zero button is depressed. On the GPIDP-A or GPIDP-V transmitter, the external zero button does a CAL AT0 calibration (at zero differential pressure). To use this feature:

1. Unlatch the external zero button by turning it 90° in a counterclockwise direction so that the screwdriver slot lines up with the two holes in the face of the adjacent part. Do **not** push the button in with the screwdriver while doing this.
2. On the GPIDP-A or GPIDP-V transmitter, press the button with zero differential pressure applied to the transmitter or the bypass valve open and the transmitter at a nonzero static pressure.
3. The display indicates **ZEROED**. If **EX ZERO** is disabled, or the transmitter is not online, the display reads **BAD KEY**.
4. If additional rezeroing is required, wait 20 seconds and repeat Step 2.
5. Relatch the external zero button by turning it 90° in a clockwise direction to prevent accidental pressing of the button. Do **not** push the button in with the screwdriver while doing this.

Configuration

You can access the Configuration mode by the same multi-level menu system that was used to enter Calibration mode. Entry to the Mode Select menu is made (from normal operating mode) by pressing the **Next** button. The display reads **CALIB**, the first item on the menu. Press the **Next** button again to get to the second item on the menu, **CONFIG**. Acknowledge your choice of this selection by pressing the **Enter** button. The display will show the first item in the Configuration menu. You can then configure items shown in Table 3 for the GPIDP-A or GPIDP-V transmitter. The initial factory configuration is also given in these tables.

Table 3. GPIDP-A or GPIDP-V Configuration Menu

Item	Description	Initial Factory Configuration(a)
EX ZERO	External zero; enable or disable	Disable
OUT DIR	Output direction; forward or reverse	Forward
OUTMODE	Output; linear or type of square root	Linear
OUTFAIL	Fail mode output; low or high	High
DAMPING	Damping; none, 2-, 4-, or 8-seconds	None

Table 3. GPIDP-A or GPIDP-V Configuration Menu (Continued)

Item	Description	Initial Factory Configuration^(a)
EGU SEL	Engineering units for calibrated range and display: Select from list if linear mode. Choose Percent or enter custom units if square root mode.	Per Sales Order for Linear; Percent for Sq Rt
EGU LRV ^(b)	Set Lower Range Value (LRV)	Per Sales Order
EGU URV ^(b)	Set Upper Range Value (URV)	Per Sales Order
DSP URV ^(c)	User defined Upper Range Value for display	Per Sales Order

(a) Default settings. If optional feature “-C2” is specified, the initial factory configuration is custom per order.

(b) This parameter is only shown when **OUTMODE** is **LINEAR**.

(c) This parameter is only shown when **OUTMODE** is one of the square root selections.

Proceed to configure your transmitter by using the **Next** key to select your item and the **Enter** key to specify your selection per Figure 24 (GPIDP-A or GPIDP-V). At any point in the configuration you may **Cancel** your changes and return to the online mode or **Save** your changes.

GPIDP-A & GPIDP-V Configuration

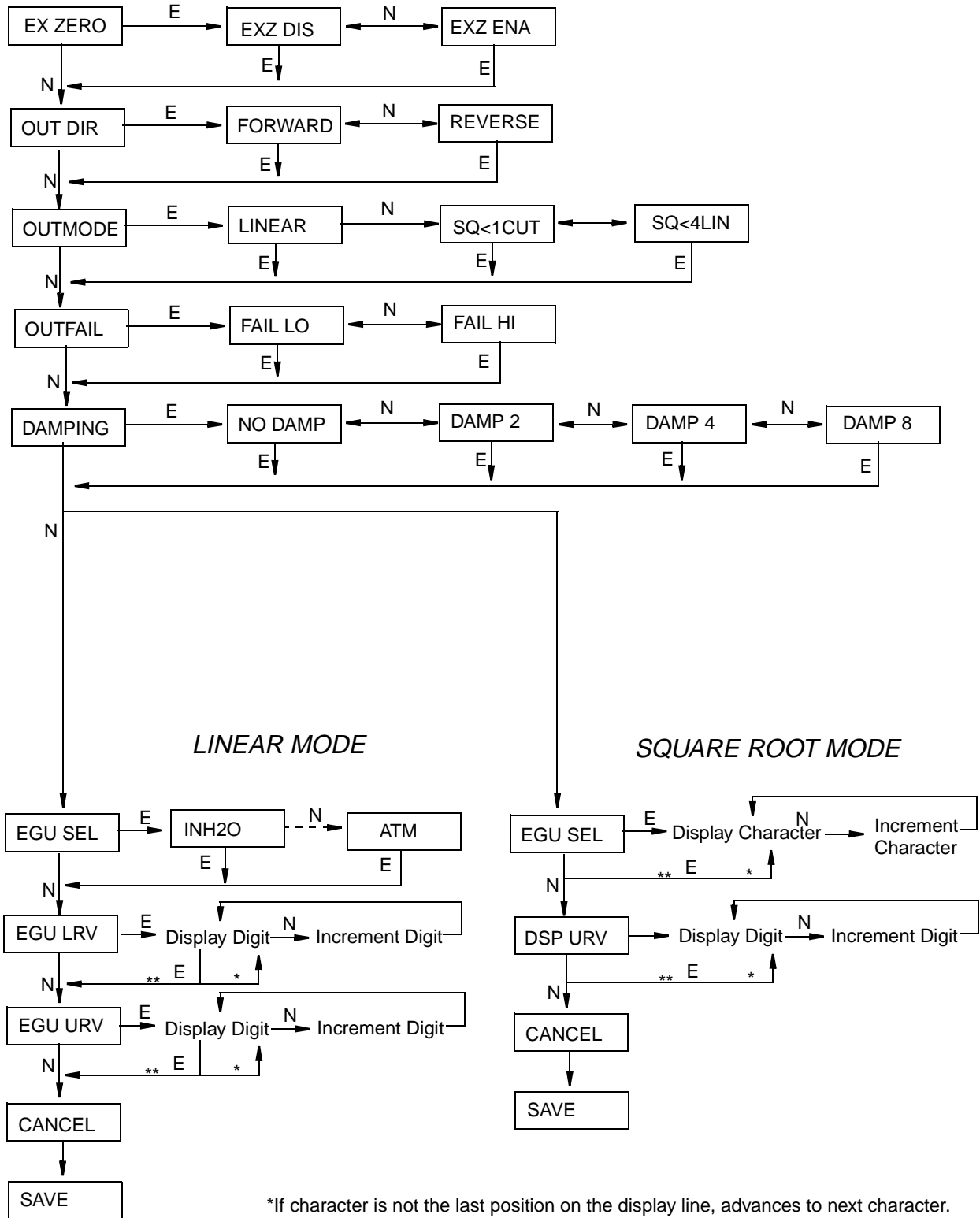

NOTE: See commentary about this diagram on next page.

Figure 24. Configuration Structure Diagram

Commentary on Figure 24

In general, use the **Next** button to select an item and **Enter** button to specify a selection.

EX ZERO: The External Zero feature allows the optional external zero pushbutton to be disabled for additional security. To configure this feature, go to **EX ZERO** with the **Next** button and press **Enter**. Use the **Next** button to select **EXZ DIS** or **EXZ ENA** and press **Enter**.

OUT DIR: To configure the Output Direction, go to **OUT DIR** with the **Next** button and press **Enter**. Use the **Next** button to select **FORWARD** (4-20 mA for GPIDP-A or 1-5 VDC for GPIDP-V) or **REVERSE** (20-4 mA for GPIDP-A or 5-1 VDC for GPIDP-V) and press **Enter**.

OUTMODE: To configure the mode of the output, go to **OUTMODE** with the **Next** button and press **Enter**. Use the **Next** button to select **LINEAR**, **SQ<1CUT** (square root with cutoff below 1% of calibrated pressure range), or **SQ<4LIN** (square root with dual slope linear below 4% of calibrated pressure range) and press **Enter**.

— NOTE —

If you wish the output and display to be in square root, it is necessary to first configure **OUTMODE** as **LINEAR** and follow the Linear Mode path in Figure 24 to establish the pressure LRV and URV. Then go back and configure **OUTMODE** as one of the square root mode selections and follow the Square Root Mode path.

OUTFAIL: The Outfail feature provides high or low output with certain malfunctions. To configure the fail mode output, go to **OUTFAIL** with the **Next** button and press **Enter**. Use the **Next** button to select **FAIL LO** or **FAIL HI** and press **Enter**.

DAMPING: To configure additional damping, go to **DAMPING** with the **Next** button and press **Enter**. Use the **Next** button to select **NO DAMP**, **DAMP 2**, **DAMP 4**, or **DAMP 8** and press **Enter**.

EGU SEL: To configure engineering units for your calibrated range and display, go to **EGU SEL** with the **Next** button and press **Enter**. Depending on how **OUTMODE** is configured, the remainder of the configuration takes one of two paths.

If **OUTMODE** was configured as **LINEAR**, use the **Next** button to select one of the following units: **INH₂O**, **INHG**, **FTH₂O**, **MMH₂O**, **MMHG**, **PSI**, **BAR**, **MBAR**, **G/CM²**, **KG/CM²**, **PA**, **KPA**, **MPA**, **TORR**, or **ATM** and press **Enter**. The display advances to **EGU LRV**.

If **OUTMODE** was configured as **SQ<1CUT** or **SQ<4LIN**, you can specify any custom display unit up to seven characters in length. The display shows **Percent** with the first character flashing. Use the **Next** button to step through the library of characters (see Table 4) to select the desired first character, then press **Enter**. Your selection is entered and the second character flashes. Repeat this procedure until you have created your new unit name. If the unit name has less than seven characters, use blanks for the remaining spaces. When you have configured the seventh space, the display advances to **DSP URV**.

EGU LRV: To configure the LRV, press **Enter** at the prompt **EGU LRV**. Use the **Next** button to toggle between a space or a minus and press **Enter**. Then use the **Next** button to step through the library of numerical characters to select the desired first digit, and press **Enter**. Your selection is entered and the second digit flashes. Repeat this procedure until you have entered your last digit. Then use the **Next** button to move the decimal point to its desired location and press **Enter**.

EGU URV: Similar to **EGU LRV** immediately above.

DSP URV: To configure the display URV in the units specified, press **Enter** at the prompt **DSP URV**. Use the **Next** button to toggle between a space or a minus and press **Enter**. Then use the **Next** button to step through the library of numerical characters to select the desired first digit, and press **Enter**. Your selection is entered and the second digit flashes. Repeat this procedure until you have entered your last digit. Then use the next button to move the decimal point to its desired location and press **Enter**.

Reranging

The GPIDP-A and GPIDP-V Transmitter can be reranged without application of pressure. To do this in linear mode, just reconfigure EGU LRV and EGU URV. To rerange the transmitter being used in Square Root mode, perform the following procedure:

1. In Configuration, set **OUTMODE** to **LINEAR**. This is a temporary state.
2. Then configure **EGU LRV** and **EGU URV**, first changing the units in **EGU SEL** if necessary.
3. Save this configuration.
4. Set **OUTMODE** back to your choice of square root mode.
5. Change **EGU SEL** and **DSP URV** if required.
6. Save this configuration.

— **NOTE** —

When **OUTMODE** is set in square root mode, the last saved pressure range set by entering **EGU LRV** and **EGU URV** in linear mode is always maintained.

GPIDP-A & GPIDP - V Character Lists

Table 4. Alphanumeric Character List

Characters
space (shown as ☒)
*
+
-
/
0 through 9
<
>
A through Z (upper case)
[
\
]
Δ
- (underscore)
∇

Table 5. Numeric Character List

Characters
-
0 through 9

Testing the Display

You can access the Test Display mode by the same multi-level menu systems was used to enter Calibration and Configuration mode. Entry to the Mode Select menu is made (from normal operating mode) by pressing the **Next** button. The display reads **CALIB**, the first item on the menu. Press the **Next** button three times to get to the fourth item on the menu, **TST DSP**. Acknowledge your choice of this selection by pressing the **Enter** button. The display shows the first test segment pattern. You can step through the five patterns by repeated use of the **Next** button. You can abort the test at any time by pressing the **Enter** button. If neither button is pressed, the display automatically steps through the five patterns in the order shown, pausing for about five seconds at each pattern and then return to the Online mode. The five patterns are shown in Figure 25.

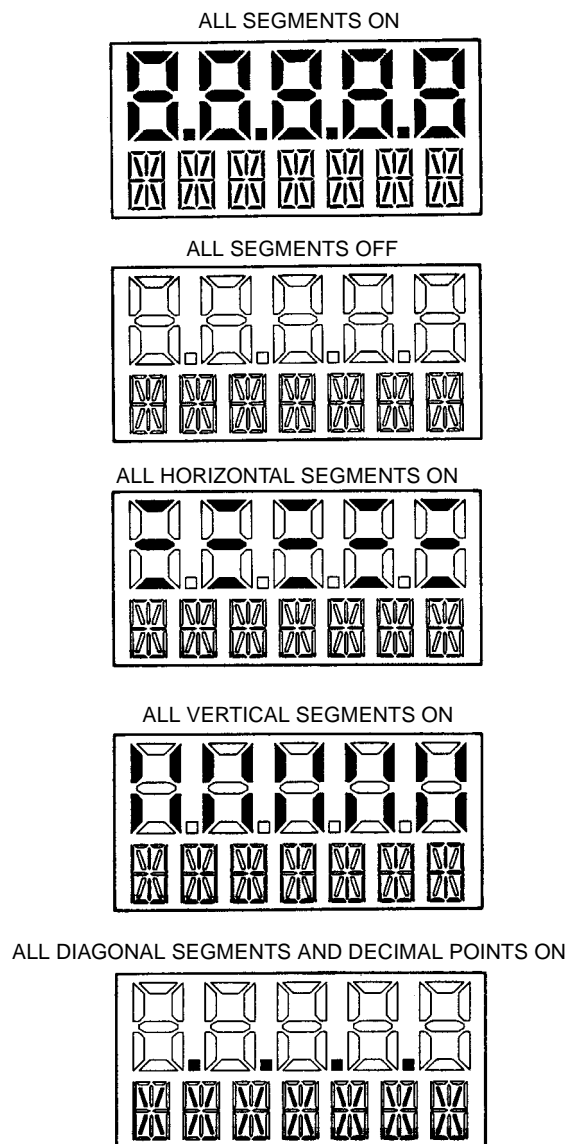

Figure 25. Display Test Segment Patterns

Error Messages

Table 6. Error Messages

Message	Interpretation
OVR RNG	Normalized calculation result greater than 2% above calibrated span. a. Overage input; correct input condition. b. Bad span calibration; recalibrate span. c. Bad sensor connection; check electronics module to sensor connection. d. Defective or damaged sensor; replace sensor.
UND RNG	Normalized calculation result greater than 2% below calibrated zero. a. Underrange input; correct input condition. b. Bad zero calibration; recalibrate zero. c. Bad sensor connection; check electronics module to sensor connection. d. Defective or damaged sensor; Replace sensor.
FDB ERR	CRC error detected in Factory Database on startup. a. Incorrect user database; replace sensor. b. Bad sensor connection; check electronics module to sensor. c. Defective or damaged sensor; replace sensor.
UDB ERR	CRC error detected in User Database on startup. a. Incorrect user database; reconfigure/recalibrate transmitter. b. Bad sensor connection; check electronics module to sensor. c. Defective or damaged sensor; replace sensor.
BAD IN1	Normalized raw pressure input outside of limits. a. Extreme overrange or underrange input; Correct input condition. b. Bad calibration; recalibrate transmitter. c. Bad sensor connection; check electronics module to sensor. d. Defective or damaged sensor; replace sensor.
BAD IN3	Normalized raw temperature input outside of limits. a. Bad sensor connection; check electronics module to sensor. b. Defective or damaged sensor; replace sensor.
BAD KEY	Invalid keypress detected a. Pressing External Zero button with EX ZERO disabled or transmitter not Online. b. Pressing Enter when transmitter is Online. c. Pressing Next or Enter while WAIT is displayed; try again after WAIT message has cleared.
LOLIMIT	Calibration adjustment has reached lower limit. a. Improper calibration setup; correct setup. b. Bad D/A converter; replace electronics module.
HILIMIT	Calibration adjustment has reached upper limit. a. Improper calibration setup; Correct setup. b. Bad D/A converter; Replace electronics module.

Table 6. Error Messages (Continued)

Message	Interpretation
BADZERO	Recalculation of offset during CAL AT0 , CAL LRV or EX ZERO resulted in out of range value. a. Applied pressure too high during operation. b. Improper calibration setup.
BADSPAN	Recalculation of slope during CAL URV operation resulted in out of range value. a. Applied pressure too low during CAL URV operation. b. Improper calibration setup.
BAD LRV	Entered value for EGU LRV is outside sensor limits.
BAD URV	Entered value for EGU URV is outside sensor limits.
BAD RNG	Recalculation of turndown during EGU LRV or EGU URV resulted in out of range value. Entered values for EGU LRV and/or EGU URV were either too close together or too far apart.
RNG>EGU	Recalculation of display value for EGU LRV or EGU URV resulted in out of range value. Selection of (linear) EGU units caused display to overflow.
LRVNOT0	Attempting mode change from LINEAR to SQ<1CUT or SQ<4LIN when EGU LRV is not 0.0.

4. Maintenance

DANGER

For nonintrinsically safe installations, to prevent a potential explosion in a Division 1 hazardous area, deenergize transmitters before you remove threaded housing covers. Failure to comply with this warning could result in an explosion causing severe injury or death.

Parts Replacement

Parts replacement is generally limited to the electronics module assembly, housing assembly, sensor assembly, terminal block assembly, and cover O-rings. For part numbers relating to the transmitter and its options, contact GP:50.

Replacing the Electronics Module

To replace the electronics module assembly, proceed as follows:

1. Turn off transmitter power source.
2. Screw in cover lock (if present) and remove the threaded electronics compartment cover by rotating it counterclockwise.
3. Remove the electronics module from the housing by loosening the two captive screws that secure it to the housing. These screws are located towards the sides of the housing. Then pull the module out of the housing.

CAUTION

The electronics module is “one assembly” at this point and is electrically and mechanically connected to topworks with a flexible ribbon signal cable, a 2-wire power cable, and in some cases, a cable for an optional external zero pushbutton. Do NOT exceed the slack available in these cables when removing the assembled module.

4. Unplug all cable connectors from the rear of the electronics module, noting the location of each cable, and place the module on a clean surface.
5. Predetermine connector orientation, then insert the cable connectors into the replacement module. Replace the module in the housing and tighten the two screws that secure it to the housing.

NOTE

To rotate display, see “Positioning Display” on page 13.

6. Reinstall the cover onto the housing by rotating it clockwise until the O-ring contacts the housing; then continue to hand tighten as much as possible (at least 1/4 turn). If cover locks are present, align the serration in the cover with the lock and unscrew it until it extends into the cover serration to prevent unwanted cover rotation.

7. Turn on transmitter power source.

The module replacement procedure is now complete.

— **NOTE** —

The transmitter configuration is stored in the sensor assembly. Therefore, the configuration settings are retained when replacing the electronics module. Recalibration, however, is recommended.

Removing and Reinstalling the Housing Assembly

To remove and reinstall the housing assembly, proceed as follows:

1. Remove the electronics module per Steps 1 through 4 in the previous procedure.
2. Remove the housing by rotating it counterclockwise (when viewed from the top) using caution to avoid damaging the ribbon cables.
3. Reinstall the housing by reversing Step 2.
4. Reinstall the electronics module per Steps 5 through 7 in the previous procedure.

Replacing the Sensor Assembly

— **NOTE** —

The transmitter configuration is stored in the sensor assembly. Therefore, the configuration settings must be re-entered after replacing this assembly. Recalibration is recommended.

To replace the sensor assembly, refer to Figure 26 and proceed as follows:

1. Remove the electronics module as described above.
2. Remove the housing as described above.
3. Remove the process covers from sensor by removing two hex head bolts.
4. Replace gaskets in process covers using new gaskets.
5. Install process covers and housing on new sensor. Torque cover bolts in several even increments to 100 N·m (75 lb·ft) [66 N·m (50 lb·ft) for bolt options B1 and D5].
6. Reinstall electronics module.
7. Pressure test the sensor and process cover assembly by applying a hydrostatic pressure of 150% of the maximum static and overrange pressure rating (see page 2) to both sides of the process cover/sensor assembly simultaneously through the process connections. Hold pressure for one minute. There should be no leakage of the test fluid through the gaskets. If leakage occurs, retighten the cover bolts per Step 5 or replace the gaskets.

—  **CAUTION** —

Perform hydrostatic test with a liquid and follow proper hydrostatic test procedures.

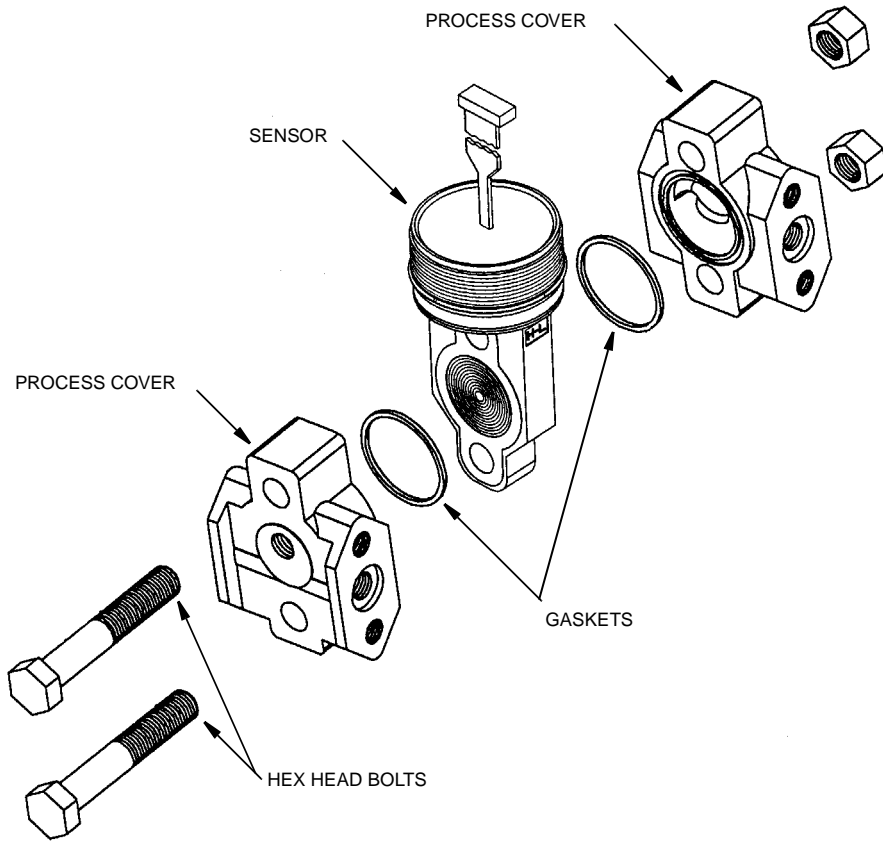

Figure 26. Replacing the Sensor Assembly

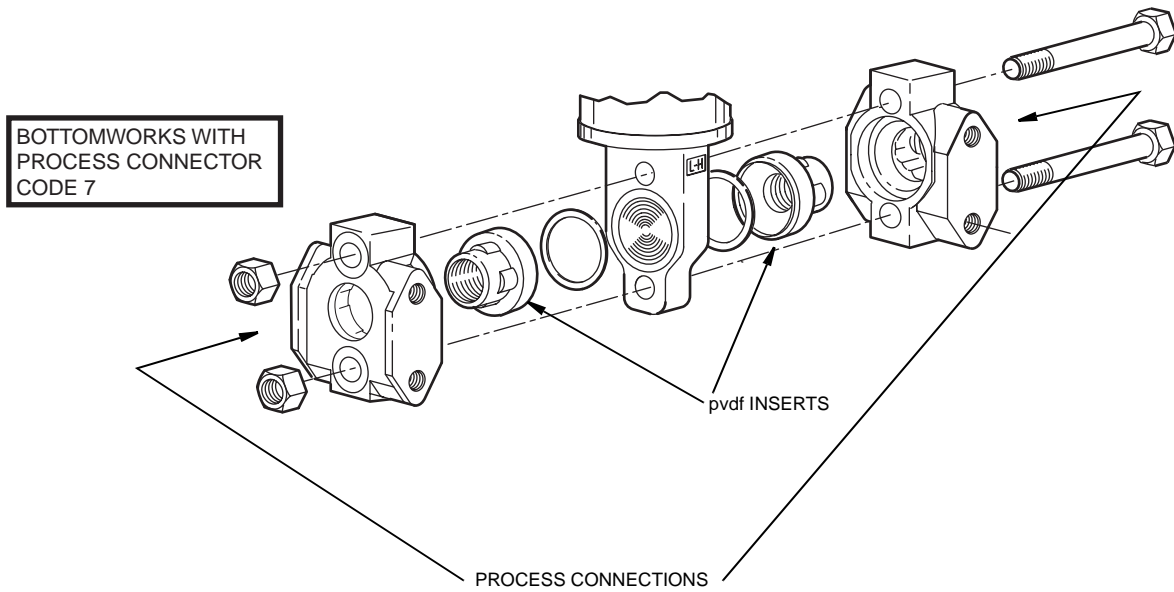

Figure 27. Replacing the Sensor Assembly (Code 78/79 pvdf Inserts)

Replacing the Terminal Block Assembly

1. Turn off transmitter power source.
2. Screw in cover lock (if present) and remove the Field Terminals compartment cover by rotating it counterclockwise.
3. Remove the four socket head screws securing the terminal block.
4. Disconnect the loop wiring connector from the terminal block.
5. Remove the terminal block and the gasket under it.
6. Install new gasket.
7. Reconnect the loop wiring connector to the new terminal block.
8. Install the new terminal block and reinstall the four screws to 0.56 N·m (5 lb·in) in several even increments.
9. Reinstall the cover onto the housing by rotating it clockwise until the O-ring contacts the housing; then continue to hand tighten as much as possible (at least 1/4 turn). If cover locks are present, align the serration in the cover with the lock and unscrew it until it extends into the cover serration to prevent unwanted cover rotation.
10. Turn on transmitter power source.

Rotating Process Covers for Venting

As received, the Transmitter provides sensor cavity draining without the need for side drain connections, regardless of whether the transmitter is mounted vertically or horizontally. Sensor cavity venting is provided by mounting horizontally or with the optional vent screw (-V). However, if you did not specify this option, you can still achieve venting (instead of draining) with vertical mounting by rotating the process covers. See Figure 28.

— NOTE —

Not applicable when pvdf inserts are specified.

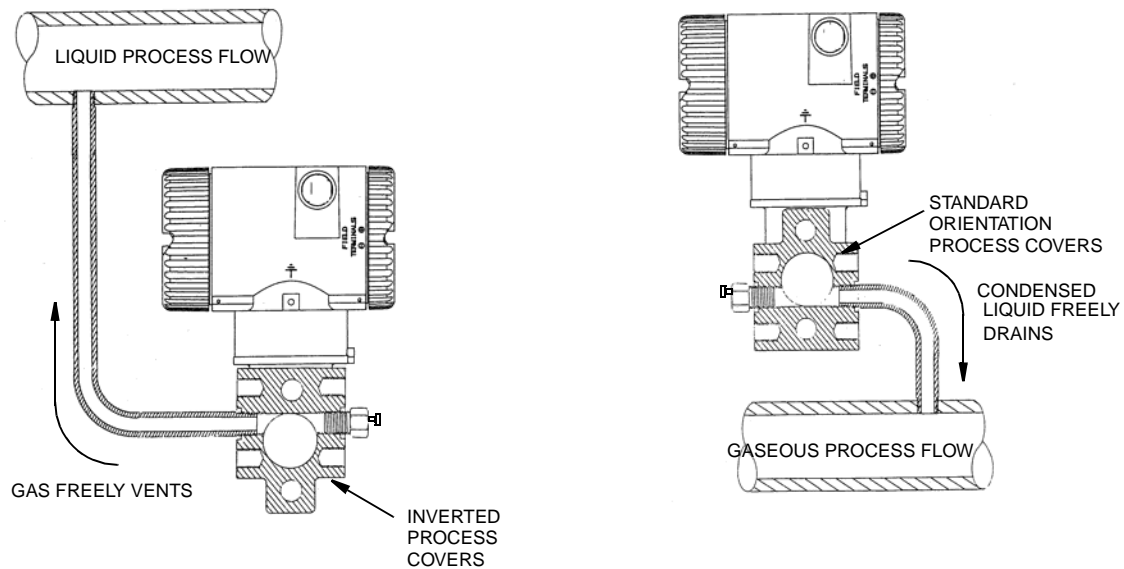

Figure 28. Sensor Cavity Venting and Draining

To rotate the process covers, refer to Figure 7 and proceed as follows:

1. Remove the process covers from sensor by removing two hex head bolts.
2. Replace gaskets in process covers.
3. Rotate the process covers so that the longer tab is at the bottom.
4. Reinstall process covers and bolts. Torque cover bolts to 100 N·m (75 lb·ft) in several even increments. Torque values are 66 N·m (50 lb·ft) when optional 316 ss bolts are specified.
5. Pressure test the sensor and process cover assembly by applying a hydrostatic pressure of 150% of the maximum static and overrange pressure (see page 2) to both sides of the process cover/sensor assembly simultaneously through the process connections. Hold pressure for one minute. There should be no leakage of the test fluid through the gaskets. If leakage occurs, retighten the cover bolts per Step 4 or replace the gaskets and retest.

CAUTION Perform hydrostatic test with a liquid and follow proper hydrostatic test procedures.

Index

B

Bench Calibration Setup 27

C

Calibration 33
Calibration and Configuration 25
Calibration Notes 28
Calibration Setup 25
Configuration 35
Cover Locks 14

E

Electronics Module, Replacing 45
Error Messages 42

F

Field Calibration Setup 25
Field Terminals 15
Filling System with Seal Liquid 13

G

General Description 1

H

Housing Assembly, Removing and Reinstalling 46

I

Identification 1
Installation 8

M

Maintenance 45
Mounting 8

P

Parts Replacement 45
Piping 9
Positioning Display 13
Positioning Housing 13
Product Safety 5
Product Safety Specifications 5
Putting Transmitter into Operation 18

R

S

Sensor Assembly, Replacing 46
Specifications 2

T

Taking Transmitter Out of Operation 18
Terminal Block Assembly, Replacing 48
Testing the Display 41

V

Venting, Rotating Process Covers for 48

W

Wiring 15

Z

Zero Adjustment Using External Zero Button 35

GP:50 NY Limited
2770 Long Rd
Grand Island, NY 14072

www.gp50.com
sales@gp50.com

Phone: 1-877-774-4751
(716) 773-9300
Fax: (716) 773-5019