



---

# ***Transducers & Transmitters***

Industrial & Aerospace Pressure Measurement

---

WWW.GP50.COM

## **HART® USERS MANUAL**

### ***GP:50 New York LTD.***

2770 Long Road  
Grand Island, NY 14072 USA

Tel. (716) 773-9300

Fax (716) 773-5019

[www.gp50.com](http://www.gp50.com)

[sales@gp50.com](mailto:sales@gp50.com)





# TABLE OF CONTENTS

---

<b>1.</b>	<b>INTRODUCTION</b> .....	1
1.1	Using this manual .....	1
1.2	GP:50 HART PRESSURE TRANSMITTERS .....	1
1.2.1	SMART .....	1
1.2.2	HART .....	1
<b>2.</b>	<b>INSTALLATION</b> .....	2
2.1	Power Supply .....	2
2.2	Current Output .....	3
2.3	Temperature .....	3
2.4	Wiring .....	3
2.5	HART Communications .....	4
2.6	The Current Loop .....	4
2.7	DD's .....	5
<b>3.</b>	<b>SETUP</b> .....	6
3.1	TAG .....	6
3.2	Descriptor .....	6
3.3	Message .....	6
3.4	Date Code .....	6
3.5	Final Assembly Number .....	6
<b>4.</b>	<b>OPERATION</b> .....	7
4.1	General Commands .....	7
4.1.1	Restore Factory Defaults .....	7
4.1.2	Write Protect .....	7
4.1.3	Damping .....	7
4.1.4	Re-Ranging .....	7
4.1.5	Alarms .....	8
4.1.6	Units .....	8
4.2	Calibration Commands .....	9
4.2.1	PV Zero .....	9
4.2.2	4-20mA Trim .....	9
4.3	Multi-drop .....	10
<b>5.</b>	<b>TROUBLESHOOTING</b> .....	11
<b>6.</b>	<b>APPENDIX A-HART REFERENCE</b> .....	12



# 1 INTRODUCTION

## 1.1 Using this manual

This manual is intended to help the end user install, maintain, and provide general service of the GP:50 line of HART pressure transmitters. No technical HART details will be provided, but enough will be presented to get a proper HART communications established. It assumes the user has a general understanding of current loops and general instrument control.

## 1.2 GP:50 HART PRESSURE TRANSMITTERS

The HART series of SMART pressure transmitters utilizes the latest electrical and mechanical technological advances to offer a stable, highly accurate pressure measurement device.

### 1.2.1 SMART

It is very important to understand that these devices are not the standard type of analog pressure transmitters. Smart implies the integration of microprocessor based calibration and control with advanced communications in addition to the analog functionality of the transmitter. With this new level of intelligent processing power, accuracy, temperature drift, non-linearity and many other error-producing factors can be reduced. It also offers the user an extended ability to calibrate the sensor in the field, as well as getting diagnostic data, transmitter status, and even secondary measurements. Gone are the days of “tweaking” pots to zero out a unit. Now, one can calibrate from a control room that may be a distance away from the unit.

### 1.2.2 HART

Highway Addressable Remote Transducer (HART) is a protocol developed by Rosemount in 1980 to enhance their process transmitters. Over the years, the protocol has gained a reputation for its diagnostic and troubleshooting ability and has developed a very strong following. Today, HART has continued to be a standardized method of industrial communication by providing a well documented set of functions, commands, and physical attributes. With this, a user can select a particular device from any manufacturer and have it function in their system with very minimal setup time. By sending messages over the current loop, HART can be operated by using the existing two-wire cabling already installed in plants. In addition, HART allows the analog current loop controlling feature to function simultaneously with digital communications without disrupting either. Because the old current loop is still operational, existing equipment can still be utilized. Today, HART is the de facto standard for existing 4-20mA current loops.

HART is now overseen by the HART Communication Foundation (HCF), which promotes, educates, and continuously develops the protocol.



## 2 INSTALLATION

### 2.1 Power Supply

For best operation, the pressure transmitter needs clean, regulated power with an output impedance less than 20 ohms. Minimum voltage is 12 volts with no resistive loading, to a maximum of 40 volts. As loads are added to the current loop (galvanic barriers, current measuring devices, resistors), the minimum excitation voltage must increase in order to maintain proper operating voltage. The graph below is the recommended voltage operating range vs. total loop resistance. Note that, for HART communications, there must be at least 250 ohms of resistance on the current loop.

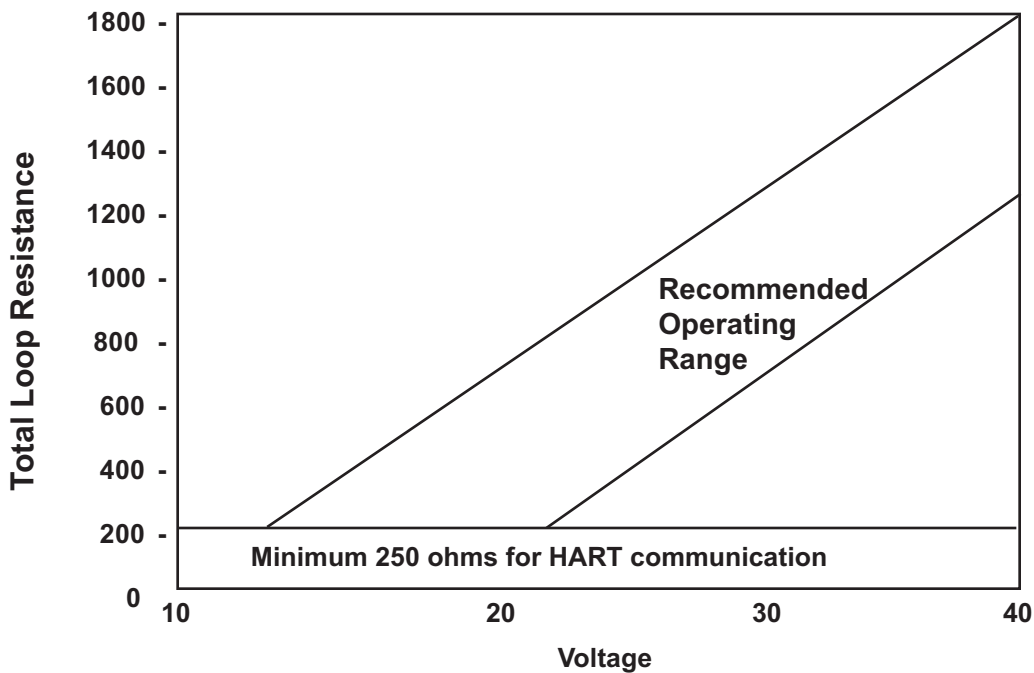

#### NOTE

In the case of accidental reversal of power leads, the unit is reverse bias protected and therefore no damage will result.

#### WARNING

Do not to under-supply voltage to the unit. Doing so may cause erratic communications and invalid readings. If the device detects a low voltage situation, a warning flag will be set in the HART communications message.

#### WARNING

The unit is over-voltage protected, but extreme over-voltage or prolonged exposure may damage input electronics and cause unit failure.



## 2.2 Current Output

During proper operation, the unit will output the standard 4-20mA signal. If a problem is encountered, the output may change depending on the Alarm Mode setting of the unit. The Alarm Mode may be changed using standard HART commands. The table below details the output of current loops based on the setting.

<b>Normal Operation</b>	<b>4.0mA – 20.0mA</b>
<b>Low Saturation</b>	3.9mA
<b>High Saturation</b>	21.0mA
<b>Low Alarm</b>	3.8
<b>High Alarm</b>	22.0

## 2.3 Temperature

The typical operating temperature range for the electronics is from 77°F (25°C) to 176°F (80°C). If the electronics in the unit exceeds this temperature, the output may drift, and after long periods of exposure, permanent damage may result. The unit should be mounted as close to the process as possible with the ambient temperature surrounding the electronics in the range as specified above.

### **WARNING**

Do not to expose electronics to long periods of extreme temperature. Doing so may cause permanent electronic damage. A warning flag will be set in the HART communications message if the electronics are getting too hot.

## 2.4 Wiring

To maintain signal integrity over long lengths of cable, use quality low-capacitance twisted pair or shielded wire cable. Do not run wires next to power lines, electrical systems, motors, generators, or any other equipment which may generate a significant amount of electrical noise or magnetic fields. If shielded cable is used, ground only one side of the cable, typically to the negative side of the power supply.

As a general rule of thumb, if the cable length is less than 5000ft, #24 AWG wire can be used. Any cable runs over 5000ft should use #20 AWG wiring.



## **2.5 HART Communications**

To communicate to the transmitter via HART, a master device is needed. Typically, this comes in one of two forms. The most common is a field portable HART 375 communicator. This is a very popular hand-held device used for minor adjustments and immediate device status. All configuration examples in this manual will assume a 375 Communicator.

The second, more permanent solution is a program running on a PC with a HART interface. There are a myriad of programs, ranging in functions and complexity, to suit different needs and requirements of the end users. Many users purchase HART server software with an OPC interface and write a custom application to fit their individual needs.

## **2.6 The Current Loop**

To set up a current loop capable of reliable HART communications, several items are needed:

- Unit with HART protocol
- Clean power supply, set to proper voltage (Section 2.1)
- 250 ohm load resistor
- Quality twisted pair or shielded wire
- HART Master (PC or 375)

The unit should be attached to the power supply with load resistor in series as shown in the picture below to create the current loop. The current meter (or any current measuring devices) can be placed anywhere on the loop, but is shown on the positive excitation in the figure below.

The two HART signal wires can either encapsulate the load resistor or the HART unit under test, as shown in the picture below. Since HART allows for two masters (Primary and Secondary), the two masters can be attached at the same points, or any combination of methods shown.

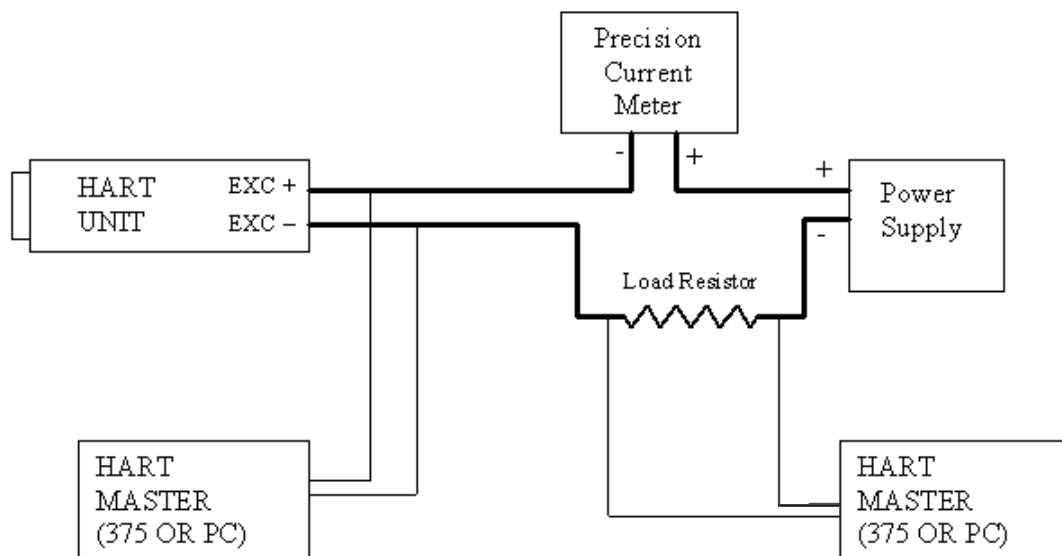

## Connecting a HART Master to the current Loop

When attaching two masters to the current loop, there can be only one primary and one secondary. Typically, the primary master will be a permanent fixed device which constantly monitors the unit, while a portable hand-held unit is configured to be the secondary.

### 2.7 DD's

Device Descriptions, or DD, is a binary file read by a HART master which describes the functionality, commands, and procedures for a particular unit. The user can run the DD on the HART communicator and will then be able to access device-specific information on the unit. Most DD's are available through the Hart Foundation, or any GP:50 specific can be obtained from the factory.

#### NOTE

Most HART masters have a "default" mode which supports a majority of the HART commands, including re-ranging, loop calibration, basic status, and configuration. So even if a particular DD is not available, the majority of functionality is still available.



## **3 SETUP**

There are several text fields on the unit that the user may wish to complete before service. They are not required for proper operation of the unit.

To change any of these properties using the HART 375 Communicator, follow these steps.

From the main menu:

1. Choose Device Setup
2. Choose Basic Setup
3. Choose Device Information

Select the desired property from the Device Information menu and follow the on-line instructions to modify the value.

### **3.1 TAG**

The TAG is the 8-character “name” of the device, typically defined by the function or location of the unit in the system. It is one of the ways a unit can be identified. In more complicated or multi-dropped setups, the TAG separates one unit from the others. If a particular unit needs to be replaced, the TAG on the new unit should be matched with the unit it is replacing. The control computer will automatically understand that a new unit has been inserted into the loop as a replacement for an older one. If a TAG name is not set up properly during a replacement, the new unit will have to be manually entered and setup in the control computer.

### **3.2 Descriptor**

The Descriptor space allows an operator to indicate which function the unit will perform, or where it is located. The Descriptor can be a maximum of 16 characters long.

### **3.3 Message**

The Message space allows an operator to leave a note to the next user, for example, unit status or the last calibration date, time, and calibrator name. The message can be a maximum of 32 characters long.

### **3.4 Date Code**

The Date Code can be used for whatever date may be useful, for example, installation date or last calibration date.

### **3.5 Final Assembly Number**

Some users assign the final assembly number to reference a drawing number or special installation information. Otherwise, it is free for whatever purpose the user wishes.



## **4 OPERATION**

### **4.1 General Commands**

The following are some of the more commonly used commands which do not directly affect the output of the unit.

#### **4.1.1 Restore Factory Defaults**

This command returns the unit to the settings as it was when it shipped from the factory. This will correct any errors made during setup or calibration of the unit which may effect the proper operation of the unit.

#### **4.1.2 Write Protect**

To protect any inadvertent changes to the setup, calibration, or message, the user can put the unit into Write Protect mode, protected by a password. Changes are only allowed when mode is disabled after a successful entry of the password. To enable Write Protection again, another password must be supplied.

This command is not part of the “standard” HART command set, and therefore, requires the device specific DD or an advanced knowledge of HART to use this command.

#### **4.1.3 Damping**

Damping is used to delay the output change by a time constant. The Damping Time Constant is defined as the time it takes for an output to reach 63% of a step input, in seconds. Damping is supported with a range of 0 to 45 seconds in increments of 100ms. If a time is entered which is not a perfect multiple, the value is rounded down to the closest allowable time value. Regardless of what the requested value was sent, the value used by the unit will be returned in the response message.

To change the Damping using the HART 375 Communicator, follow these steps.

From the main menu:

1. Choose Device Setup
2. Choose Basic Setup
3. Choose PV Damp

Enter the Damping value, in seconds.

#### **4.1.4 Re-Ranging**

One of the most common operations is to re-range the transmitter. This gives the user much flexibility in process control. This can be done by either entering the upper and lower range values manually, or can vary the pressure on the system and allowing the transmitter to create the range by “sampling” the process for both upper and lower points.



If the transmitter detects that the range chosen by the user is too small, it will reply with a message warning that the overall accuracy may be compromised due to the small range values chosen.

Although HART allows the current loop to be flipped, where maximum pressure is 4mA and zero pressure is 20mA, it is not supported in this device.

To manually change the range using the HART 375 Communicator, follow these steps.

From the main menu:

1. Choose Device Setup
2. Choose Diag/Service
3. Choose Calibration
4. Choose Enter Values

From the Enter Values menu, select either the Lower Range Value (LRV) or Upper Range Value (URV) to edit the value per process requirements.

#### **4.1.5 Alarms**

If a catastrophic failure occurs to any of the on-board sensors or electronics (as determined by the initial self-test or continuous self checking), the unit will default to user-determined course of action. The user can select the response as High (22mA), Low (3.8mA), Hold Last Value, or None. If an error occurs, the Device Malfunction and More Status Available bits will be set in the Response Codes regardless of how the alarm mode is set.

Setup of this command is not part of the “standard” HART command set, and therefore, requires the device specific DD or an advance knowledge of HART to use this command. The default alarm mode is “None.”

#### **4.1.6 Units**

The units in which pressure is reported may be modified. GP:50 HART units currently support PSI, BAR, TORR, ATM and kg/cm<sup>2</sup>.

To change the Pressure units using the HART 375 Communicator, follow these steps.

From the main menu:

1. Choose Device Setup
2. Choose Basic Setup
3. Choose PV Unit

Scroll up or down to choose the new pressure unit.



## 4.2 Calibration Commands

The following are some of the commands which directly affect the calibrated output of the unit.

### NOTE

If errors are made in these calibration commands which cause the unit to behave unexpectedly, the Restore Factory Defaults command may be used to restore the unit. This command will reset everything to original factory setup.

### 4.2.1 PV Zero

The zero of the unit may drift slightly over time or with non-uniform temperature gradients across the unit at process temperature. This shift may be compensated for by “re-zeroing” the unit.

To re-zero the unit verify there is no pressure is applied to the unit.

From the main menu

1. Choose Device Setup
2. Choose Detailed Setup
3. Choose Sensors
4. Choose Pressure
5. Choose Zero trim

Follow the on line instructions to complete the calibration.

### 4.2.2 4-20mA Trim

The loop current may be calibrated by using a precise current measurement instrument.

To calibrate the loop output using the HART 375 Communicator, follow these steps.

From the main menu:

1. Choose Device Setup
2. Choose Diag/Service
3. Choose D/A Trim

Follow the on-line instructions to complete the calibration.

### 4.3 Multi-drop

One of the more unique properties of the HART protocol is the ability to multi-drop transmitting devices on a single pair of wires. Multi-dropping is simply having two or more devices share the same single cable. This gives the advantage of running multiple devices at the same time without running a cable for each unit. The only drawback is that every device in multi-drop mode cannot control the 4-20mA current loop. Each device is then required to put out a constant current, typically 4mA. The number of devices a single cable can support depends on cable length, type, and device input characteristics, up to a maximum of 15 devices.

Each device is assigned a unique “poll” address, from 1 to 15. This means that a single master HART controller can access 15 different transmitter devices. The following diagram details a typical multi-dropped setup, with a single master.

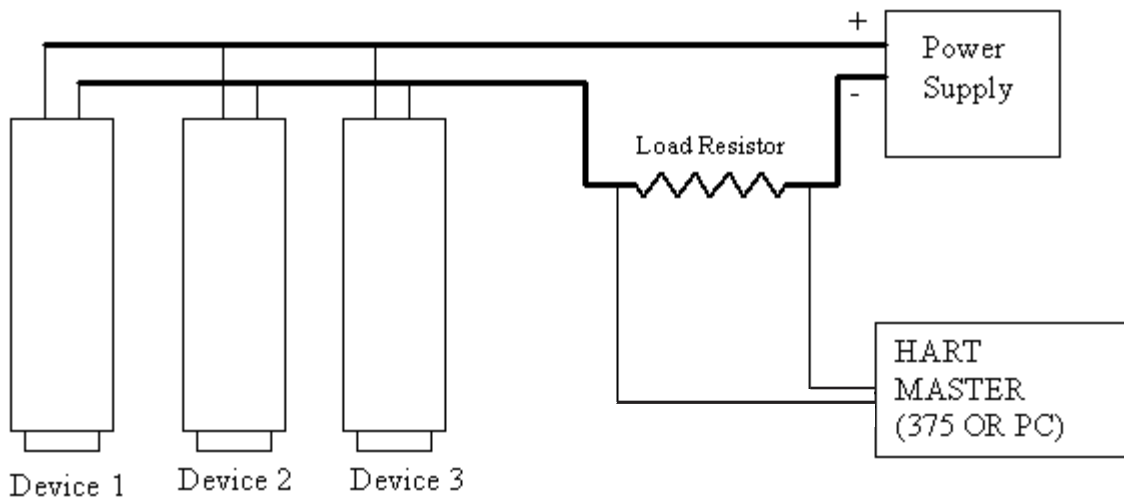

#### Multi-dropped HART Devices

Poll Address 0 represents a device NOT in multi-drop mode and has complete control of the current loop. When a unit is shipped from the factory, the poll address is preset to 0. This allows a unit to be inserted into a current loop whether or not if there is HART communication present. To place the device on a network, assign the poll address a unique number (1-15) using the HART communicator. Assigning the poll ID of the device to something other than 0 automatically disables the current loop control, and will only draw 4mA.

To change the Poll Address using the HART 375 Communicator, follow these steps.

From the main menu:

1. Choose Device Setup
2. Choose Detailed Setup
3. Choose Output Condition
4. HART Output
5. Poll Addr

Enter the poll address for the unit from 0 to 15.



## **5 TROUBLESHOOTING**

If a unit is not working properly, the following may help determine which corrective action to take.

### **Unit not responding**

- Unit wired correctly?
- Load resistor in loop?
- Loop excitation voltage?
- HART leads hooked up properly in correct spots?
- Primary and Secondary Masters set up properly?

### **Erratic Communication**

- Large enough loop resistance (> 250 ohms)?
- Too much loop resistance?
- Proper loop excitation voltage?
- Cable running near power cables or large equipment?
- Try .1uF capacitor across + and – of power supply.

### **Slow Response**

- Port clogged?
- Incorrect damping time constant?

### **Improper Output**

- Manual current mode enabled?
- Alarm active?
- Upper/Lower Range set correctly?
- Multi-Drop mode (Polling Address incorrect)?
- Re-Zero required?

If the problem persists, please call the factory for assistance and have the following information ready:

- Serial number
- Model number
- Loop setup – power supply, resistor, cable routing/length, Multi-drop
- Any error messages displayed by the master?
- Status bits of HART message?
- What action caused devices to fail?

For service, please contact the repair department at GP:50:

- sales@gp50.com
- 716-773-9300



## 6 APPENDIX A - HART REFERENCE

### Response Codes

#### First Byte:

Bit 7=0	Command Response
0	No Command Specific Error
2	Invalid Selection
3	Passed Parameter Too Large
4	Passed Parameter Too Small
5	Too Few Data Bytes Received
6	Device-Specific Command Error
7	In Write Protect Mode
8-15	Multiple Meanings (see Table Below)
16	Access Restricted

Bit 7=1	Communication Error
Bit 6	Parity Error
Bit 5	Overrun Error
Bit 4	Framing Error
Bit 3	Checksum Error
Bit 2	Reserved
Bit 1	Rx Buffer Overflow
Bit 0	Reserved

#### Second Byte:

Device Status	
Bit 7	Field Device Malfunction
Bit 6	Configuration Changed
Bit 5	Cold Start
Bit 4	More Status Available
Bit 3	Analog Output Fixed
Bit 2	Analog Output Saturated
Bit 1	Non-Primary out-of-limits
Bit 0	Primary Variable out-of-limits

Not Used
Second byte is not used when a communication error is indicated by the first byte.

#### Multiple Meaning Command Response Table

Code	Meaning
8	Update Failure Set to Nearest Possible value Update in Progress
9	Lower Range Value Too High Applied Process Too High Not in Proper Current Mode
10	Lower Range Value Too Low Applied Process Too Low
11	Upper Value Too High In Multidrop Mode
12	Upper Range Value Too Low Invalid Units Code
13	Both Range Values Out Of Limits
14	Span Too Small Pushed Upper Range Over Limit