



Pressure, Level & Temperature Transmitters & Transducers

2770 Long Road, Grand Island, NY 14072 USA

Tel. (716) 773-9300 • Fax (716) 773-5019

sales@gp50.com • www.gp50.com

SPACE QUALIFIED IN-FLOW, LIGHTWEIGHT, LOW NOISE PRESSURE TRANSDUCER

Model 7901 “S” Class Electronics Available

Designed for the tough challenges and environmental rigors of space propulsion and aviation pressure testing.

FEATURES:

- <3 mV peak-to-peak noise on output
- Under 55 grams mass (depending on desired options)
- High Accuracy, 0.3% RSS standard (0.1% RSS available)
- “S” Class electronics available
- Rad-Hard 100 KRAD optional
- Flow-Thru design
- Isolated outputs for EMI/RFI
- Optional temperature compensation ranges
- Temperature (RTD) output optional
- Shock and Vibration tested to MIL-STD-810C&E requirements

Typical Applications:

- Miniature Propulsion Platforms
- Space Vehicles
- Satellite Propulsion
- Launch Vehicles
- Life Support Systems



Heritage Includes:

- NASA Goddard
- NASA Marshall

All GP:50 Aerospace pressure transducers are manufactured and tested to the following MIL-STD and MIL-Spec standards to insure the highest quality assurance:

- NIST Traceability and Calibration..... MIL-STD-45662A
- Workmanship J-001 / NASA 8739.3 standards
- Quality System ISO 9001:2008

Designed to: MIL-STD-810 C&E
MIL-STD-461/462 D&E

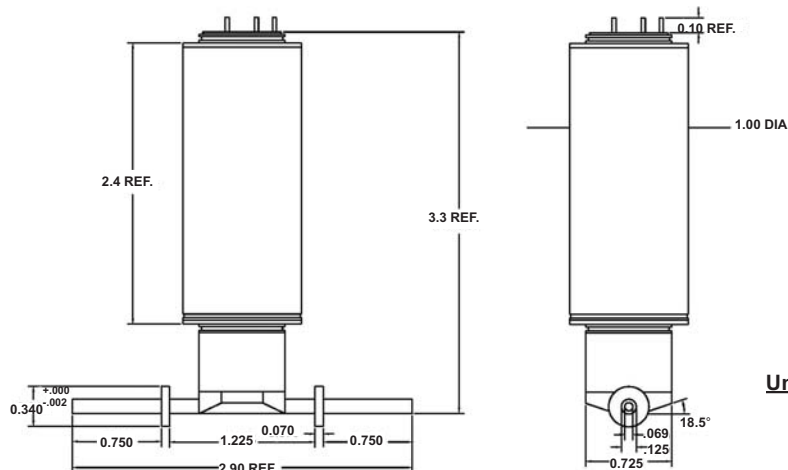

Units are in inches

A5SL-7901.00 Rev B

GP:50 reserves the right to make product improvements and amendments to the product specifications stated throughout this brochure without prior notification. Please contact the factory on all critical dimensions and specifications for verification.



Pressure, Level & Temperature Transmitters & Transducers

2770 Long Road, Grand Island, NY 14072 USA

Tel. (716) 773-9300 • Fax (716) 773-5019

sales@gp50.com • www.gp50.com

Specifications and options reflect standard product, other improved performance / mechanical / electrical / options available, consult factory for more information. Modifications may alter specs.

Ranges	15 thru 5,000 PSIA, PSIG or PSISG options
FS Output at Rated Pressure	3 mV/V, 0-5 Vdc Isolated, 0-10 Vdc Isolated
Proof Pressure	1.5X
Burst Pressure	2.0X
Excitation or Input Voltage Reverse Polarity Protected	5 Vdc, 12Vdc, 18V to +36 Vdc Isolated
Non-Repeatability	<0.1% FSO
Non-Linearity	<0.2% FSO
Hysteresis	<0.2% FSO
Static Accuracy RSS	<0.3% FSO RSS, 0.1% optional
Error Band (all 5 parameters)	1.0% standard
Pressure Medium (Wetted Materials)	316SS
Temperature Compensation	-20° to +120°F / -30° to +50°C, expanded range optional
Operating/Environmental Temperature	-100°F to +250°F
Weight	<55 grams
Pressure Port	Welded 1/4" ID SS Tube, flow through, in-line design (other ports available)
Electrical Connector	MIL PTIH-10-6P (other connectors available)
Response Time	< 4ms
Meets MIL-STD-461/462 EMI/RFI & 810C & E	Some options will affect EMI/RFI rating

ORDERING GUIDE:

Some options will affect dimensions, consult factory if important.
Use the following codes to identify desired item.

MODEL	OUTPUT	RANGE	PRESSURE TYPE	OPTIONS
●	+	●	+	●

Example: 7901-2-RH-A-CA/FD/GH

OUTPUT

- 1 0-3 mV/V
- 4 0-5 Vdc Isolated
- 6 0-10 Vdc Isolated

RANGE (PSI)

- PP 0-15 RK 0-750
- PR 0-20 RM 0-1000
- PO 0-25 RO 0-1500
- PV 0-50 RR 0-2000
- PZ 0-100 RT 0-3,000
- RB 0-150 RV 0-5,000
- RD 0-200
- RF 0-300
- RH 0-500

PRESSURE TYPE

- A Sealed Absolute, ref to vacuum
- G Gauge, ref to atmosphere
- SG Sealed Gauge, ref to 14.7 PSI

OPTIONS

CONNECTORS OR CABLE:

- CA PTIH-10-6P Bendix
- CI D38999/27YB98PN
- CT 36" Teflon Jacket Cable
- DB D38999/27YA35PN

PORTS

- FA MS33649-4, 7/16-20 (F)
- FD MS33656-4, 7/16-20 (M)
- IF Welded 1/8" ID SS Tube

MISC:

- D Improved Accuracy to 0.1%
- GF Expanded process temperature range, -65 to 250°F (±2% FSO/100°F)
- GH 100% Internal Shunt
- GL Cleaning for oxygen service
- JA 100 ohm 2 wire RTD
- JB 1000 ohm 2 wire RTD
- ME Shunt Cal, 80% Internal