



PRESSURE TRANSDUCER FOR CRYOGENIC ENVIRONMENTS

Model 7720

Designed for the tough challenges and environmental rigors of space propulsion and aviation pressure testing.

- High Vibration Environments
- Extreme or Harsh Environments
- Manifolds, Propulsion Systems
- Military and Defense Applications

FEATURES:

- High accuracy, 0.3% RSS standard (0.1% available)
- -320°F to +70°F standard medium
- Lightweight, 8 ounces
- Hydrogen and LOX compatibility
- Custom probe lengths, 1.55" standard
- Designed to meet vibration and shock per MIL-STD-810



All GP:50 Aerospace pressure transducers are manufactured and tested to the following MIL-STD and MIL-Spec standards to insure the highest quality assurance:

- NIST Traceability and Calibration..... MIL-STD-45662A
- Workmanship J-001 / NASA 8739.3 standards
- Quality System ISO 9001:2000

Designed to: MIL-STD-810C&E
MIL-STD-461/462D&E

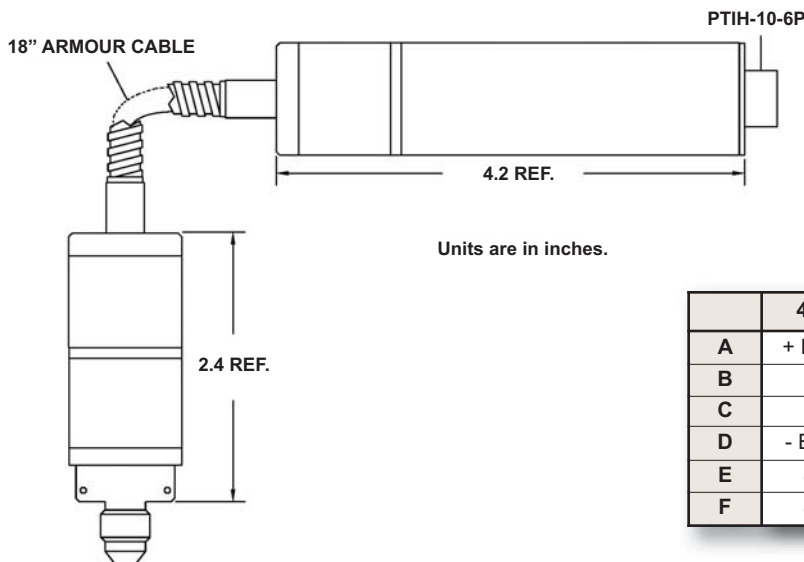

	4-20 mA PIN OUT	Vdc / mV/V PIN OUT
A	+ EXC./SIGNAL OUT	+ EXC.
B	NC	+SIGNAL OUT
C	NC	-SIGNAL OUT
D	- EXC./SIGNAL OUT	- EXC.
E	SHUNT OPTION	SHUNT OPTION
F	SHUNT OPTION	SHUNT OPTION

GP:50 reserves the right to make product improvements and amendments to the product specifications stated throughout this brochure without prior notification. Please contact the factory on all critical dimensions and specifications for verification.



Pressure, Level & Temperature Transmitters & Transducers

Specifications reflect standard product, improved performance/mechanical options available. Modifications may alter specs, consult factory for more information.

Ranges	15 thru 15,000 PSIA, PSIG or PSISG options
FS Output at Rated Pressure	3 mV/V at 10 Vdc / 0-5 Vdc / 4-20 dcmA Isolated options
Temperature Output	100 ohm 2 wire platinum RTD optional, 1000 ohm 2 wire platinum RTD also available
Excitation or Input Voltage Reverse Polarity Protected	18 to 36 Vdc / 9 to 36 Vdc Unregulated
Non-Repeatability	<0.1% FSO
Non-Linearity	<0.2% FSO
Hysteresis	<0.2% FSO
Static Accuracy RSS	<0.3% FSO RSS, 0.1% optional
Pressure Medium (Wetted Materials)	316SS (Inconel, Hastelloy, Monel optional)
Operating / Environmental Temperature	-320°F to +70°F / -200°C to +20°C
Weight	8 oz. (approx.)
Electrical Connector	MIL PTIH-10-6P, D38999 series III optional
Response Time	Under 4 ms
Meets MIL-STD-461/462 EMI/RFI	Some options will affect EMI/RFI rating
Flex Tubing	18" Armored Capillary Tube

ORDERING GUIDE:

Some options will affect dimensions, consult factory if important.
Use the following codes to identify desired item.

MODEL	OUTPUT	RANGE	PRESSURE TYPE	OPTIONS
●	—	●	—	●

Example: 7720-2-RH-G-CA/FD/GH

OUTPUT

- 1 3 mV/V
- 2 0-5 Vdc 4 wire hookup
- 3 4-20 dcmA
- 4 0-5 Vdc Isolated
- 5 0-10 Vdc 4 wire hookup
- 6 0-10 Vdc Isolated
- 7 2 mV/V
- 8 10 mV/V
- 9 0-5 Vdc 3 wire hookup
- 10 0-10 Vdc 3 wire hookup

RANGE (PSI)

- PP 0-15 RK 0-750
- PR 0-20 RM 0-1000
- PO 0-25 RO 0-1500
- PV 0-50 RR 0-2000
- PZ 0-100 RT 0-3000
- RB 0-150 RV 0-5000
- RD 0-200 RX 0-7500
- RF 0-300 RZ 0-10,000
- RH 0-500 SB 0-15,000

PRESSURE TYPE

- A Sealed Absolute, ref to vacuum
- G Gauge, ref to atmosphere
- SG Sealed Gauge, ref to 14.7 psia

OPTIONS

CONNECTORS:

- CA PTIH-10-6P Bendix
- CI D38999/27YB98PN
- DB D38999/27YA35PN

PORTS:

- FA MS33649-4, 7/16-20 (F)
- FD MS33649-4, 7/16-20 (M)

MISC:

- D Improved Static Accuracy to 0.1% and Total ErrorBand to 1.0%
- GB Alternate Full Scale Outputs
- GH 100% Internal Shunt
- GK Inconel Pressure Cavity
- GL Cleaning for oxygen service
- GP Hastelloy Pressure Cavity
- GU Monel Pressure Cavity
- JA 100 ohm 2 wire RTD
- JB 1000 ohm 2 wire RTD
- ME Shunt Cal, 80% Internal

FLEX TUBING:

- GT 30" Armored Capillary Tube
- HS 9" Armored Capillary Tube
- HV 24" Armored Capillary Tube
- HY 12" Armored Capillary Tube
- MT non-standrad Armored capillary Tube (50" max)