



**MELT PRESSURE  
TRANSDUCERS & TRANSMITTERS**  
2770 Long Road, Grand Island, NY 14072 USA  
Tel. (716)773-9300 • Fax (716)773-5019 • sales@gp50.com • www.gp50.com

## Product Specification Sheet

### DIGITAL PRESSURE CONTROLLER

#### Model 1270

The 1270 1/4 DIN indicator is designed with an easy to use programmable faceplate and two alarms relative to set point (bottom display).



#### SPECIFICATIONS:

- Two layer 4-digit LED display
- Ranges 0.100-9999 psi (Radix point changeable)
- 0.001 display resolving quotiety
- 85-265 VAC excitation
- 92 x 92 mm
- Operating range 0-55°C

Pressure upstream and downstream programmable alarms, and RS232, RS485 serial communication. Pressure programmable analog output: 4-20 mA, 1-5 Vdc, 0-5 Vdc, 0-10 Vdc.

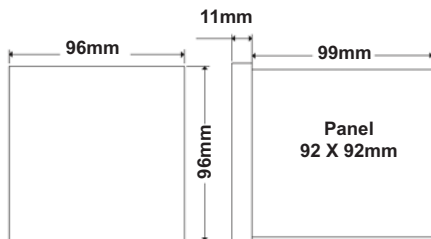
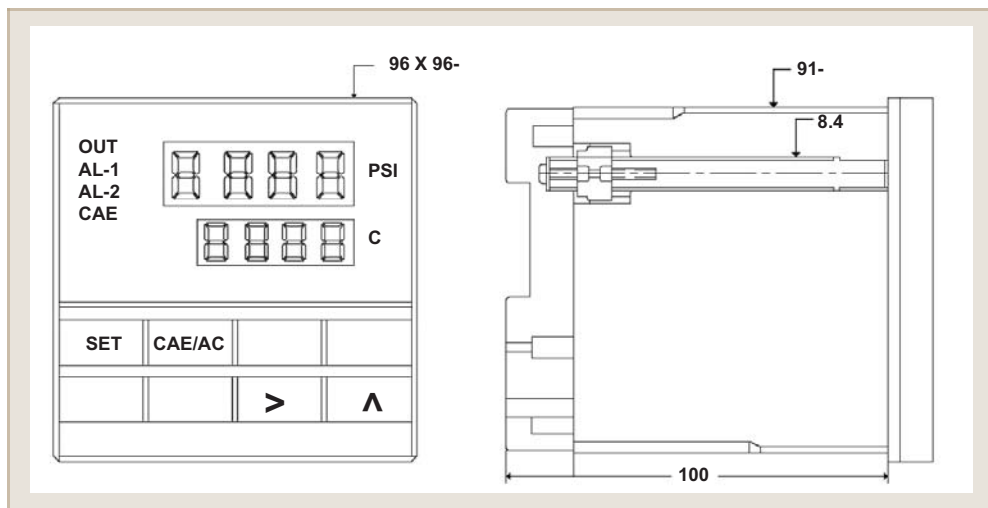

#### WIRING CODE

- |       |                           |
|-------|---------------------------|
| 1     | SIGNAL +                  |
| 2     | EXCITATION -              |
| 3     | SIGNAL                    |
| 4     | EXCITATION                |
| 5     | CALIBRATION               |
| 6     | BLANK                     |
| 7     | AL-2+, RS-485 output A    |
| 8     | AL-2-, RS-485 output B    |
| 9     | AL-1 +                    |
| 10    | AL-1 -                    |
| 11/12 | OUT on                    |
| 12/13 | OUT off                   |
| 14/15 | Alternating current input |
| 16    | GROUND                    |

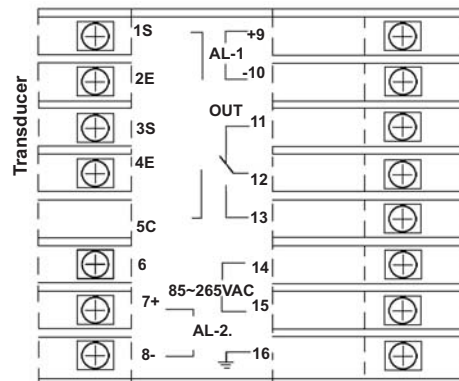

GP:50 reserves the right to make product improvements and amendments to the product specifications stated throughout this brochure without prior notification. Please contact the factory on all critical dimensions and specifications for verification.



**MELT PRESSURE  
TRANSDUCERS & TRANSMITTERS**

2770 Long Road, Grand Island, NY 14072 USA  
Tel. (716) 773-9300 • Fax (716) 773-5019 • sales@gp50.com • www.gp50.com

**OPERATING FLOW CHART**

**Main Display State**

